

A Macro View of Shadow Banking:

Levered Betas and Wholesale Funding in the Context of Secular Stagnation

By Zoltan Pozsar¹

DRAFT

(as of 1/31/2015)

Abstract

The literature to date on shadow banking has focused on the wholesale funding and private money creation aspects of shadow banking. This paper draws attention to those aspects of shadow banking that involve leveraged betas and the provision of excess returns over fixed income benchmarks. Broadening the discussion from net to gross repo, the paper highlights the role of broker-dealers as matched-book money dealers that stand between cash pools in search for safety, and various kinds of leveraged bond portfolios across the asset management complex in search for yield. This broader perspective shows deep linkages between shadow banking and asset management, including not only hedge funds but also what are assumed to be unleveraged, “long-only” mutual funds. Whereas cash pools’ problem is the structural shortage of safe, short-term, public assets (a shortage of public money), real money investors’ problem is structural asset-liability mismatches driven by the secular decline of yields on safe, long-term, public assets relative to “sticky” return targets/expectations. The secular rise of leveraged betas (that is, the secular increase in the use of both cash and synthetic forms of leverage in bond portfolios) has been asset managers’ way of helping real money investors bridge structural asset-liability mismatches through the provision of “equity-like returns with bond-like volatility”. To that end, the use of repo and securities lending by bond portfolios across the asset management complex exceeds the use of repo by banks and broker-dealers to fund their own bond portfolios and inventories, respectively. The “sucking sound” of asset-liability mismatches driving the secular rise of levered betas, financed through the absorption of cash pools’ money demand – “the leveraged bids glut” – is a powerful alternative to Bernanke’s “global savings glut” and Shin’s “global banking glut” hypotheses for the decline in the Treasury term premium and the compression of mortgage and other spreads before the 2008 crisis. Crowding out private money by boosting the volume overnight Federal Reserve RRP’s or of U.S. Treasury bills would fix cash pools’ problems, but deepen real money investors’ asset-liability mismatches. More even-handed policies include “Dealer of Last Resort” and fixing imbalances in present incomes and future (pension) promises – a joint application of these policies would complement the G20/FSB reform agenda to date to find a better balance between the economic benefits of deep and liquid markets, and the financial stability risks inherent in the (gross) balance sheet intensity of the provision of deep and liquid markets.

¹ For Lena and little Emma. The author is a founding member of the Shadow Banking Colloquium, a project of the Financial Stability Research Program of the Institute for New Economic Thinking (INET). This paper is a culmination of several conversations over the past three years with George Akerlof, James Aitken, Viktoria Baklanova, Terry Checki, Stijn Claessens, Giovanni di Iasio, Perry Mehrling, Daniel Neilson, Elena Liapkova-Pozsar, Phil Prince, Morgan Ricks, Matt Rutherford, James Sweeney, Eric van Wetering and Jonathan Wilmot. For comments, thanks to seminar participants at the Bank of England, the International Monetary Fund, U.S. Treasury, OFR, the Federal Reserve Board, the FDIC, the ECB, the ESRB, the Institute for New Economic Thinking (INET) and the Central European University.

Introduction

The aim of this paper is to provide a mile-wide and inch-deep macro perspective into shadow banking, one that gets much more to the fundamental drivers of shadow banking than the largely descriptive and more micro-oriented original by [Pozsar, Adrian, Ashcraft and Boesky, 2010](#). The aim of the 2010 paper was to put shadow banking on the radar of economists, policy makers and market participants – mapping the system and identifying “credit, maturity and liquidity transformation by non-banks without access to official liquidity and credit puts” as its hallmarks were just a first step.

But a proper analysis and monitoring of shadow banking should be about more than just scanning and policing the financial ecosystem for credit, maturity and liquidity transformation by non-banks. It is also about who should play a bigger role in the provision of money to institutional cash pools – “shadow banks” or the sovereign; how the proliferation of structural asset-liability mismatches among real money investors drove demand for investment strategies that promise equity-like returns with bond-like volatility, typically delivered in the form of levered beta exposures; and how various forms of leverage provided by broker-dealers to these investment strategies across the asset management complex help generate excess return for real money investors as a first order priority, influences the yield of Treasury securities and spreads on mortgages and other bonds, and provides balance sheet capacity for the provision of credit to borrowers in the real economy as a byproduct.

Accordingly, this paper emphasizes the role of shadow banking as the process through which the financial ecosystem resolves the structural shortage of Treasury bills – and more broadly, public money – on the one hand, and increasingly inadequate expected returns on safe bonds on the other.

Wholesale funded, levered bond portfolios – money market funding of capital market lending – whether on the balance sheet of global banks, broker-dealers or funds across the asset management complex effectively serve a dual purpose: first, the provision of quasi Treasury bills through the issuance of shadow money claims to fill the structural shortage of genuine Treasury bills available for institutional cash pools to park their funds in, and second, the provision of excess returns with low volatility – equity-like returns with bond-like volatility – to those who provide the equity “tranche” of levered bond portfolios: shareholders in financial holding companies (in the case of global banks’ and dealers’ bond portfolios) and the ultimate investors that invest in levered bond funds. In this framework, shadow money claims raise the short-term funding, short-term funding provides the leverage (the source of maturity transformation and “carry”), and leverage boosts expected returns.

To date, the literature has focused on the funding and money creation aspects of shadow banking (see [Pozsar, 2011](#), [Gorton and Metrick, 2012](#), and [Stein, 2012](#)), but not its excess return aspects.

A discussion of this role of shadow banking and related policy considerations are the paper’s key focus and contribution to the literature on shadow banking. The genesis of a lack of attention to the excess return aspects of shadow banking may have been the singular attention to net repo in the literature and relative under-appreciation of gross, or matched-book repo. Dealers’ role as matched-book money dealers in the financial ecosystem is the untold story of repo. As this paper explains, repo in the context of matched-book money dealing differs from repo’s canonical interpretation as a “bonds-funded-by-repos” analogue of the “loans-funded-by-deposits” balance sheet of banks.

Matched-book repo is about dealers' role as both massive borrowers and lenders in the secured money market, intermediating between risk-averse cash pools on the one hand and risk-seeking, levered fixed income portfolios on the other, with the aim of using cash from the former to provide leverage to the latter to generate returns over a benchmark at low volatility for pension funds and other real money accounts that have been struggling with rising asset-liability mismatches since 2000.

The paper has six parts as follows.

Part one describes the hierarchy of money in the modern financial system; defines shadow banking; and identifies cash pools as the fundamental drivers behind the rise of wholesale funding markets.

Part two describes the fundamental drivers behind the secular rise of levered fixed income investing; how wholesale funding and levered fixed income investing are essentially flip sides of the same coin; and how broker-dealers emerged as intermediaries between two tribes of portfolio managers – one seeking safety and the other yield – and as providers of working capital for the latter much like real bill brokers provided working capital for merchants and manufacturers in Bagehot's world of yore.

Part three discusses data gaps in measuring leverage in the broader asset management complex and perception gaps between reality and what the economic literature and textbooks would have one believe about the lack of explicit forms leverage in traditional, "long-only" bond mutual funds. Improvements to financial accounting would help us see beyond Bernanke's savings glut hypothesis and Shin's banking glut hypothesis as the only possible reasons behind the pre-crisis compression of the Treasury term premium and mortgage spreads, respectively, and see these developments also as a result of the massive run-up in the volume of levered bids for these securities coming from asset managers, financed through broker-dealers' matched repo books – "the leveraged bids glut".

Part four interprets the hallmarks of shadow banking – wholesale funding and levered fixed income investing – as the financial economy reflections of the very same real economy imbalances that are behind the recently revived idea of secular stagnation (see [Summers](#), 2013), and reconciles all this with the view that shadow banking is a manifestation of financial globalization (see [Mehrling](#), 2013).

Part five discusses three sets of policy options around shadow banking: first (and least likely) reforming the financial ecosystem, which include redistributive measures to address the various forms of real economy imbalances that drove the secular rise of shadow banking (see Pozsar, [2013](#) and [2014](#)); second, dealer of last resort (see [Carney](#), 2014, [Mehrling](#), 2010 and [Mehrling et al](#), 2013); and third, increasing the supply of public money for institutional cash investors through reverse repos issued by the Federal Reserve or tilting the U.S. Treasury's issuance schedule toward more Treasury bills (see [Greenwood, Hanson, Rudolph and Summers](#), 2014 and Pozsar, [2011](#) and [2012](#)).

Finally, part six concludes the paper.

Part I – Wholesale Funding

A useful way to frame and measure the size of the shadow banking system is through the question of what is "money" for large, institutional cash investors.

Money and money-like claims refer to overnight and short-term liabilities that can be converted into payments system money in the form of a demand deposit at par or near par on demand. Money and money-like claims have no to minimal credit and duration risk and are hence highly liquid. For those who invest in them, they refer to a particular subset of safe assets, namely safe, short-term assets.

Not all money and money-like claims are created equal: their par and near par on demand nature is not uniformly strong in all states of the world. One way to rank them is according to the type of assets backing them and the type of backstops supporting them, which may be public or private. This yields four categories of money and money-like claims (henceforth “money”): public money, insured money and shadow money, which may be either public or private (see [Pozsar, 2014](#)).

Figure 1 shows these four types of money in a matrix where each quadrant corresponds to a distinct set of issuing entities, each entity with a quintessential form of money-liability that corresponds to it.

In the upper-left quadrant are public money claims. These are reserves issued by the Federal Reserve and bills issued by the U.S. Treasury. Both claims are backed by public assets – U.S. Treasury debt and government-guaranteed mortgages, and the government’s authority to tax, respectively – and are direct liabilities of the sovereign. They are the safest of safe assets in the financial ecosystem.

In the lower-left quadrant are insured money claims. These are demand and term deposits issued by local banks in amounts less than \$250,000. Insured money claims are private-public money as they are backed by private sector loans but are supported by explicit public backstops in the form of liquidity puts to the Federal Reserve and credit puts to the U.S. Treasury through deposit insurance.

In the upper-right quadrant are public shadow money claims. These are overnight and term repurchase agreements (repos) backed by government-guaranteed collateral and issued by the rates desks of broker-dealers, and constant net asset value (NAV) shares issued by government-only money market funds that invest only in the above repos and short-term U.S. Treasury obligations.

Public shadow money claims are public-private money as they are backed by public assets and are private promises to pay par or near par on demand, reinforced by private, not public backstops. That said, because the assets backing them are public and hence credit-risk free, public shadow money claims have an implicit credit put to the sovereign, and because these assets are central bank eligible, they are also supported by an implicit liquidity put to the central bank. These implicit puts make public shadow money nearly as strong as public and insured money, but not quite as strong.

In the lower-right quadrant are private shadow money claims. These are overnight and term repos backed by private collateral issued by the credit desks of broker-dealers; constant NAV shares issued by prime money market funds that invest in the above repos and other short-term, unsecured liabilities issued mostly by banks but also by financial holding companies and non-financial firms; and uninsured demand and term deposits issued by global banks in amounts greater than \$250,000.²

Private shadow money claims are purely private money as they are backed by private assets and are private promises to pay par or near par on demand, reinforced by private, not public backstops – public backstops are not present, not even implicitly. This is true even in the case of global banks’

² Global banks refer to U.S. chartered banks with overseas operations and the New York branches of foreign banks.

uninsured deposits which are supported by liquidity puts to the Federal Reserve, but not by credit puts to the sovereign. Private shadow money claims are the weakest of the four categories of money.

Figure 2 shows the core entities of the shadow banking system – broker-dealers and money funds – on the right-hand side of the matrix. The shadow money claims issued by them, together with the uninsured deposits of global banks, represent where the bulk of credit, maturity and liquidity transformation is conducted without the twin pillars of public liquidity and credit backstops available to traditional banks (see [Pozsar et al, 2010](#)). Put differently, these parts of the matrix represent where the bulk of money market funding of capital market lending takes place (see [Mehrling et al, 2013](#)).³ Importantly, as the purple borders in Figure 3 indicate, shadow banks co-exist with traditional banks under the financial holding company umbrella of global systemically important banks (G-SIBs).

An essential first step to understand the secular rise of wholesale funding, and why the supply of certain types of money grew faster than others before the Great Financial Crisis is to divide cash investors into two groups: retail and institutional. The economics literature and textbooks universally assume that the bulk of intermediaries' funding comes from households and that wholesale funding is mostly an interbank phenomenon – institutional cash investors feature nowhere in the debate.⁴

This misperception is important to highlight as an increasing share of intermediaries' funding has been coming from large, institutional cash investors – or institutional cash pools. Cash pools refer to investors with at least \$10 billion in money market assets under management, and are managed by professional investors whose mandate is “do not lose” (see Pozsar, [2011](#), [2012](#) and [2014](#)).

Cash pools fall into three categories: first, the liquidity tranche of FX reserves; second, the cash pools of global corporations; and third, cash pools in the asset management complex (see Figure 4).⁵

Unlike retail cash investors, who hold cash mostly for real economy transactions, institutional cash pools hold cash balances mostly for financial economy transactions – for the daily fixing of FX pegs, and for supporting the increased liquidity needs of the modern asset management complex, which stem mostly from the rising prominence of derivative-overlay investments (where “cash” is used as a fundamental building block of portfolios) and securities lending (to be discussed in Part IV).

Cash pools are relatively recent species in the global financial ecosystem – FX reserves took off in earnest after the Asian financial crisis and China's entry into the world trading system in 2000; corporations have become net suppliers of funding in the financial system also after 2000 in contrast to their traditional role as net demanders of funding; and the structural increase in the cash intensity of asset management and consolidation among asset managers are fairly recent phenomena as well.

³ Money market funding of capital market lending as a definition of shadow banking elegantly implies the presence of maturity and liquidity transformation (money market funding) as well as credit transformation (capital market lending). That said, credit transformation only applies in the case of private credit claims, not credit-risk free public credit claims.

⁴ Even if cash pools ultimately reflect retail claims, the fact that they are managed by professional investors matters: once retail cash balances get aggregated they become wholesale (institutional) cash pools, going from insured to uninsured, and from principal to agent investments, with the latter highly sensitive to counterparty risks and thus highly run prone.

⁵ Cash pools within the asset management complex refer to the cash pools that arise due to the central liquidity management of fund complexes, the cash balances of institutional investors ranging from pension and insurance funds to hedge funds and endowments, and the cash collateral reinvestment accounts of seclenders (previous works (see Pozsar 2011 and 2014) refer to three or four types of pools, depending on whether seclenders are counted separately).

Figure 5 shows the volume of cash pools over time. Notice the sharp pickup in the growth of cash pools after 2000, which is to say that the growth in cash pools pre-dates the Great Financial Crisis, and that cash pools kept on growing in the aggregate in the aftermath of the Crisis – two pieces of evidence that underscore the secular, as opposed to cyclical nature of the rise of cash pools. Here it is also important to note that cash pools in the asset management complex dominate (more on this in Part II of the paper), followed by corporate pools; the liquidity tranche of FX reserves ranks last.

Size matters. Unlike retail cash investors for whom money exists in the form of currency and insured deposits, institutional cash pools have no (or only limited) access to the public and insured money claims listed on the left-hand side of the matrix. This is because cash pools cannot have reserve accounts at the central bank, and their size is far above the deposit insurance limit of \$250,000.

Were cash pools to invest in an uninsured deposit at any single bank, they would assume an unsecured and undiversified counterparty credit risk vis-à-vis that bank, which is imprudent and would not get any risk manager's approval. And what is true at the micro level is also true at the macro level, as cash pools have grown ever bigger, while options to diversify unsecured bank exposures have been shrinking due to consolidation among banks best able to absorb pools of cash. These issues have been further exacerbated by the fact that the same banks have often been serving as providers of credit lines and derivative and trading counterparties to cash pools and the larger, consolidated entities they belonged to. This was a further constraint for cash pools to keep cash in uninsured deposits, as that would have led to an increase in the concentration of counterparty risks.

Thus, after a point, demand for uninsured deposits becomes inelastic, and adjustments in prices are unable to clear markets (see [Claessens et al, 2012](#)). As a result, cash pools start to diversify out of the banking system and look for money and money-like claims elsewhere in the financial ecosystem.

Treasury bills are one alternative. As a form of public money, Treasury bills represent the safest of safe assets that cash pools can invest in. However, both an analysis of the so-called monetary premium embedded in the yield of Treasury bills (see [Greenwood, Hanson and Stein, 2014](#) and Figure 6), and an analysis of the balance between the supply of and demand for Treasury bills (see [Pozsar, 2011](#)) suggest that the financial ecosystem is beset by a structural shortage of Treasury bills.

Figures 7 and 8 show how on the left-hand side of the matrix, institutional cash pools are effectively stuck between a rock and a hard place: an inelastic supply of public money claims as cash pools as a whole cannot get enough Treasury bills (the paradox of safe investing, see [Pozsar, 2012](#)), and an inelastic demand for uninsured bank deposits as after a point, cash pools are unwilling to assume unsecured counterparty credit risk exposure to banks. Ultimately, this is what makes cash pools to opt for second best alternatives by investing in the elastic “middle” of shadow money claims on the right-hand side of the matrix. While not as safe as Treasury bills, secured repos issued by dealers and the diversified exposure to unsecured claims that prime money fund shares represent are safer claims than an unsecured credit exposure to any single bank through uninsured deposits (see [Pozsar, 2014](#)).

In fact, Figure 9 confirms that cash pools, unlike households, hold only a limited amount of their cash balances in M2-types of money. Whereas insured deposits are the dominant form of money for households, uninsured deposits make up only about 20% of institutional cash portfolios. Thus, for institutional cash pools “money (practically) begins where M2 ends”. Importantly, as explained by [Pozsar, 2014](#), the volume of uninsured deposits held by institutions is likely overstated by the

numbers in Figure 9, as some uninsured deposits are only marginally above the deposit insurance limit and are held by households and small businesses, not cash pools. But since a granular breakdown of the size of uninsured deposits by size is not available, it is impossible to estimate with current data the precise volume of uninsured deposits held by cash pools. This is an important, but highly under-appreciated data gap: although data on what types of institutional investors hold how much in Treasury bills, institutional-class money fund shares and repos is also far from perfect, there is a lot less data (or more bluntly, practically no data) about the holders of bank deposits and a breakdown of holdings by function, term and size (see [OFR](#), 2013 and Pozsar, 2015a, forthcoming).

What this implies is that any discussion of “core” *vs.* “noncore” (that is, deposit versus non-deposit) liabilities should be context dependent – both from a liability, as well as an asset perspective.

The core versus noncore characterization of liabilities has been shaped by analyzing peripheral cases – Northern Rock in the U.K. (see [Shin](#), 2010a) and South Korean banks’ noncore liabilities which have historically been denominated by U.S. dollar borrowings (see [Shin](#), 2010b). However, the picture looks completely different at the core of the dollar-based global financial system as depicted by the money matrix (also see [Mehrling](#), 2011 and [Mehrling et al](#), 2013), where certain types of core intermediaries, such as broker-dealers, fund their balance sheets exclusively using noncore repos, and where cash pools – as an increasingly dominant group of funding providers in the financial ecosystem – prefer to invest in noncore secured liabilities (repos) that put them in a legally senior position relative to core liabilities such as uninsured deposits, or in the case of unsecured liabilities, they prefer to hold them indirectly through shares in diversified prime money fund portfolios.

Put differently, looking at the full range of money claims from a demand versus a supply perspective, usual classifications are stood on their head: as show by Figure 9 what are typically referred to as financial intermediaries’ core liabilities are noncore assets in institutional cash portfolios, and what are usually referred to as intermediaries’ noncore liabilities are core assets in institutional cash portfolios – and that includes Treasury bills which don’t even count as money in the mainstream economic literature and textbooks (exceptions include Pozsar, [2011](#) and [2014](#), Greenwood, Hanson and Stein, [2010](#) and [2014](#) and Krishnamurthy and Vissing-Jorgensen, [2013](#)).

Part II – Levered Betas

Having covered the sources of wholesale funding, the paper now turns to the uses of wholesale funding. The aim of this part of the paper is to describe the role of broker-dealers as matched-book money dealers and as intermediaries between cash pools and leveraged bond investors, and how wholesale funding and leveraged fixed income investing are essentially flipsides of the same coin.

One key insight of this part of the paper is that leverage is present not only in hedge fund portfolios, but also what are traditionally assumed to be unleveraged, long-only mutual funds. The aim of the discussion is not to quantify relative degrees of leverage in various fixed income portfolios, but [1] to catalogue the presence of leverage (regardless of how small or large) in various forms and places across the broader asset management complex; [2] to identify reasons for the creep of leverage even into traditional corners of asset management; [3] to highlight the role of matched-book money and risk dealing in the provision of leverage; and [4] to have a better sense of the aggregate volume and the ultimate uses and users of wholesale funding sourced through the repo market. As the pages below describe, leverage in asset management sourced through securities financing transactions has

declined since 2008, but at over \$2 trillion it still remains significant. In contrast, the volume of leverage incurred through the use of derivatives has increased (see IMF, 2014 and also Aitken, 2014).

Wholesale funding and banking being topics that go hand in hand, and banking universally associated with lending to the real economy, the canonical view is that all forms of wholesale funding ultimately fund the extension of credit to the real economy. While this is true, it is not true that all of this credit intermediation happens on the balance sheet of global banks or broker-dealers and is hence supported by the capital base of these intermediaries. It also happens on the balance sheet of a range of levered bond funds across the asset management complex where it is supported by the risk capital of the ultimate investors who placed their savings with these levered funds.

Of the intermediaries listed in the money matrix, broker-dealers are perhaps the least well understood when it comes to the question of who exactly they lend to. We know what local banks do – they make loans to households and small businesses and issue demand deposits in the process, in small, insured amounts (see [Turner](#), 2013, [Kumhof and Jakab](#), 2014 and [McLeary et al](#), 2014).

We also know what global banks do – they too make loans and issue deposits, but typically to global businesses and in large, uninsured amounts. In addition, we also know that global banks manage large fixed income portfolios which they fund in the wholesale funding market (see [Eatwell](#), 2013), and serve as money dealers in the domestic federal funds and GCF repo markets, and between the domestic and Eurodollar funding markets through interoffice loans and interest rate and FX swaps (see [McGuire and von Peter](#), 2009, [Shin](#), 2011, [Stein](#), 2012, [Mehrling](#), 2013 and [Pozsar](#), 2014). In all of these cases, we have a good sense of which sectors of the economy banks' bond portfolios fund, and an increasingly good sense of the volume and geographic distribution of global dollar funding.⁶

And we know what money funds do – they absorb funds by offering par on demand claims and re-lend funds in the money market to four major borrowers: the Federal Reserve via reverse repos; the U.S. Treasury via Treasury bills; global banks, both on and offshore, via Yankee and Eurodollar instruments; and broker-dealers via repos. Money funds also lend to the government-sponsored enterprises (GSEs) via agency discount notes, and to financial and bank holding companies as well as to non-financial firms via the commercial paper market, but in relatively small amounts. Here too, the question of who money funds lend to (and at what tenor and price) is fairly clear and obvious.

But we do not know too well who broker-dealers fund with the funds they raise. This is mostly due to data gaps in the bilateral repo market, where all of the short-term funds raised by broker-dealers are re-lent, also on a short-term basis. What we do know is that only a relatively small portion of the short-term repo funding raised by broker-dealers is used to fund dealers' inventories of long-term securities (an analogue of global banks' wholesale-funded bond portfolios), and that their bulk ends up being passed on to institutional clients through reverse repo loans (through matched, or close to matched books). This suggests that broker-dealers, similar to global banks and money funds, also function as money dealers but mostly onshore and near-exclusively in the secured money market.⁷

The canonical view on what broker-dealers do is quite different from this, however. It casts dealers as entities that use repo mainly to fund their own securities inventories – an image that yields

⁶ Money dealing refers to market making both within and across onshore and offshore (Eurodollar), and secured and unsecured money markets between banks, broker-dealers, money funds and levered bond investors globally.

⁷ This is in contrast to global banks and prime funds who also deal in offshore as well as unsecured money markets.

misplaced conceptual parallels with the “loans-funded-by-deposits” balance sheet of banks. Furthermore, it assumes that securities financing transactions involving bond collateral are mostly inter-dealer and dealer-to-bank, and that securities financing involving equities (margin lending) through prime brokerage is all there is to the interaction between broker-dealers and asset managers.

The remainder of this section of the paper aims to de-bunk these misconceptions and shed light first on the volume of money dealing conducted by broker-dealers, and second the type of securities and clients that they fund in the process. It also identifies deeper macroeconomic themes that may explain why we have seen a secular increase in the volume of securities financing in the run up to the crisis – the flipside of the secular rise of institutional cash pools over the same time period.

First, money dealing.

Figure 10 shows the volume of primary dealers’ securities financing activities over time. The blue line plots “securities in” which refers to cash lent by broker-dealers versus securities collateral through reverse repo transactions, as well as securities borrowed by broker-dealers versus cash collateral through securities borrowing transactions. The red line plots “securities out” which refers to cash borrowed by broker-dealers versus securities collateral through repo transactions, as well as securities lent by broker-dealers versus cash collateral through securities lending transactions.⁸ As these lines demonstrate, broker-dealers are at the same time both massive borrowers and lenders (that is, money dealers) in the secured money market, and, as noted above, only use a small share of short-term funding raised via repos to fund their own inventory of securities held for market making purposes. The latter is shown by the orange line, which plots “net financing”: the difference between total securities out (funding raised by dealers) and total securities in (funding provided to clients).

Figure 11 shows a snapshot of the balance sheet of primary dealers as a sector at two points in time: before the Great Financial Crisis (the first quarter of 2008) and more recently (the first quarter of 2013). From bottom to top, the snapshots show the portion of dealers’ securities inventories funded on a long-term basis (shades of red), the portion of dealers’ securities inventories funded on a short-term basis (shades of blue) and finally, the portion of dealers’ matched-book money dealing activities (shades of yellow). As shown very explicitly by this figure (and as implied by Figure 10 above), just over 80% of broker-dealers’ balance sheet (a number unchanged since the Crisis) is accounted for by matched-book money dealing, that is the intermediation of cash versus securities between clients long securities and in need of funding, and cash pools long cash and in need of collateral.

Figure 12 shows a more granular look at the composition of broker-dealers’ matched-book activities by term. Thus, roughly 50% of dealers’ client financing is conducted on an overnight basis and the other half on a term basis, and on the funding side, the split between overnight versus term funding of money dealing is about 70% to 30% – ratios that also have not changed much since the Crisis. Contrast this with the portrayal of overnight repo borrowing by others (see [Brunnermeier, 2009](#)) that focus on the dominance of overnight repo borrowings of broker-dealers, without due regard to the equally dominant volume of overnight repo loans of broker-dealers – as a matter of fact, overnight lending to the buy side can only be financed overnight for money dealing to be profitable.

⁸ While some securities financing transactions involve the swap of securities for securities, most are securities for cash.

Figures 13 and 14 show that about 60% of broker-dealers' balance sheet – another ratio that did not change much since the Crisis – supports matched book money dealing (overnight borrowing to fund overnight lending and term borrowing to fund term lending as denoted by those slices of the figure that are marked with an “=” sign); that about 20% of broker-dealers' balance sheet involves the overnight funding of term financing extended to clients (long inventories of money market exposure that arose out of money dealing); and that the remaining 20% of broker-dealers' balance sheet is typically dedicated to fund inventories of securities held for market-making purposes – a segment where funding has decidedly shifted from short-term to longer-term since the Great Financial Crisis.

Second, funding what and for whom?

Figure 15 shows that the volume of securities financing transactions that go through dealers' financing operations and involve bonds as collateral (excluding inter-dealer and dealer-to-bank trades in the GCF[®] repo market; see the red and blue lines), outstrip the volume of transactions that flow through dealers' prime brokerage operations backed by equities collateral (see the orange lines).

Figure 16 presents the same from the vantage point of hedge funds, by showing how leverage sourced through prime brokerage accounts for less than 20% of hedge funds' funding, and leverage sourced through repos (through dealers' financing desks) and derivatives (through dealers' derivative (swap) desks) account for a much bigger 50% and 30% of hedge funds' total funding, respectively.

Both Figure 15 and Figure 16 sit uncomfortably with the notion that broker-dealers lend mostly to hedge funds, through prime brokerage operations, and mainly involving equities collateral. In contrast, what these figures suggest is that further inquiry into who is on the receiving end of dealers' financing activities leads us beyond the world of long/short equity hedge funds and deep into the realm of asset management and the world of levered bond portfolios (see [Pozsar, 2014](#)).

Figure 17 shows the three core categories of levered bond portfolios: mutual funds, hedge funds and separate accounts with rates (that is, fixed income) and/or credit (as opposed to equity) mandates. These types of vehicles account for the bulk of bond portfolios in the asset management complex.

Just like cash pools, levered bond portfolios are also fairly recent species of the financial ecosystem, and also took off around the turn of the millennium. While their rise is hard to track in the data (due to the bilateral repo data gaps mentioned above), it can be inferred from some investment methods that were first devised and written about by leading asset managers in the early 2000s (see [Gross, 2003a](#) and [2003b](#) and [Dalio, 2004](#)), and later adopted by many others across the financial ecosystem.

The fundamental macro drivers behind the secular rise of levered bond portfolios were two-fold: over-concentration in equities and inadequate returns on safe, long-term assets (see [Dalio, 2004](#)) – problems that came to the fore after the burst of the dot com bubble and subsequent decline in long-term interest rates, which in turn triggered a structural widening of asset-liability mismatches at institutional investors such as pension funds and FX reserve managers (see Figure 18; structural asset-liability mismatches will be discussed in more detail below and in Part IV of the paper).

In turn, these events drove the demand from institutional investors for products with mandates to “beat the benchmark” by delivering equity-like returns with bond-like volatility (see [Sweeney, 2012](#)).

Examples of such products, across the three categories of levered bond portfolios mentioned above, include the largest total return, absolute return and risk parity funds among mutual funds; strategies including credit and fixed income arbitrage (including agency mortgage REITs) among hedge funds; and among separate accounts, funds that are either bespoke and/or blended versions of the above or are solutions-driven (i.e., liability-driven investments) to help investors meet fixed obligations (regarding leverage in risk parity funds, also see for example [Asness, Frazzini and Pedersen, 2012](#)).⁹

Although to varying degrees, each and every one of these investment strategies involve the engineering of targeted risks and returns using leverage, either through the use of securities financing such as repos and securities lending, or through the use of derivatives such as futures and swaps (note, that the emphasis of this paper is on the role of securities financing, not derivatives; the remainder of this paper discusses derivatives mostly in the context of how margin calls associated with derivatives may necessitate the raising of liquidity through securities financing transactions; the use of derivatives in asset management varies: as described in Pozsar, 2015b derivatives are used not only to gain leverage, but also to hedge, and to gain exposure to a segment of the market “when the combination of derivatives and short-term instrument [that is, cash and cash equivalents] provide a more attractive risk-return profile than they physical alternative” (see [PIMCO, 2014](#)), or when physical instruments are in short supply relative to demand (for example, broker-dealers’ provision of 30-year Treasury exposures via 30-year swaps, or EM exposures through credit-linked notes).

For example, in the case of risk parity funds, [Dallo, 2004](#), describes how using leverage, bonds can be made competitive with equities at lower levels of risk. Similarly, in the case of total return funds, [Gross, 2003a](#), notes “Holy cow, Batman, [leveraged bond portfolios] can outperform stocks” on a risk-adjusted basis. More generally, [Gross, 2003b](#), argues how during periods of negative real short-term interest rates and/or sharply positive yield curves, investors should invest in assets that borrow at the short-term rate, not lend at them – a strategy where bond portfolio managers effectively raise cash either through borrowing against or lending their Treasury securities in the repo and securities lending markets, respectively, or by building Treasury exposures through the use of futures and swaps (which require little cash upfront), and use the proceeds to purchase commercial paper and floating rate notes issued by global banks, broker-dealers and financial and non-financial corporates. In essence, such investment techniques turn Treasuries into “corporate bonds in disguise” (see [Gross, 2014a](#)), allowing the manager of a Treasury fund to beat the benchmark, not by generating alphas (through market timing and security selection), but leverage-enhanced betas ([Gross, 2014b](#)).¹⁰ Finally, in the case of hedge funds, agency mortgage REITs running funded (that is, levered) portfolios of agency mortgage-backed securities are a fairly straightforward example of levered betas (other examples would include fixed income arbitrage hedge funds and long/short credit funds).

Figure 19 shows how the engineering of all forms of levered betas involve the use of borrowed cash for three distinct ends: funding, shorting (and on the flipside of shorting, securities lending), and derivatives margining. In the case of funding, cash is needed for the funding of levered bond positions; in the case of securities lending/shorting, cash is needed as collateral in exchange for fixed income securities loaned/borrowed; and in the case of derivatives, cash is needed for margining

⁹ In effect, institutional investors’ aim was to reduce allocations to high return, but high volatility stocks, and at the same time replace the sacrificed returns by increasing allocations to levered positions in low return, but low volatility bonds.

¹⁰ Leverage-enhanced betas (or simply, levered betas) are also referred to as “perceived alphas” (see [Gross, 2014b](#)) or “smart betas” (see [Foley, 2014](#)). Both terms imply the creep of leverage into what are traditionally thought of as long-only fixed income strategies, and the creep of shadow banking-like activities into the asset management complex.

purposes (for examples of each see the three balance sheets on the left-hand side of Figure 19, and a more detailed description of each example see [Pozsar, 2014](#) sections III.1.a, III.1.b and III.1.c). Bilateral repos, securities lending and swaps conducted with dealers – as intermediaries between levered bond funds on the left and cash pools on the right-side of Figure 19 – play a role in all of these transactions as denoted by the lines that run through dealers’ matched repo and swaps books.

Figure 20 shows a simplified version of Figure 19 and depicts a “pocket version” of the dealer ecosystem where broker-dealers act as money and risk dealers between two tribes of portfolio managers: cash pools searching for safety and levered bond portfolios searching for yield (this model was developed by the Shadow Banking Colloquium at the Institute for New Economic Thinking, see the paper “Bagehot Was a Shadow Banker” by [Mehrling, Pozsar, Sweeney and Neilson, 2013](#)).

As discussed in Part I, cash pools are cash rich but “safety poor” since they are too large to be eligible for insured money and face a structural shortage of Treasury bills. This drives them toward shadow money claims such as repos collateralized by bonds. On the other hand, levered bond portfolios are securities rich but “return poor” in the sense that they have a mandate to beat their benchmarks. To that end, they employ the techniques of funding, securities lending and derivatives. In each and every one of these cases, levered bond portfolios repo securities out and cash in, and on the other side, cash pools repo securities in and cash out. Cash pools get their safety (thanks to the securities posted by levered bond portfolios as collateral) and levered bond portfolios get their enhanced return in the form of leverage-enhanced betas (using the funds provided by cash pools *vs.* collateral). In this sense, cash pools and levered bond portfolios are complements to each other. As more than just brokers, broker-dealers not only intermediate between cash pools and levered bond portfolios through matched books, but also absorb imbalances in order flows, which give rise to inventories – sometimes short (term funding of overnight exposures) and sometimes long (overnight funding of term exposures) – mismatched positions against which dealers hold capital.

This image of the dealer ecosystem allows us to draw powerful parallels between the activities of the London bill brokers of Bagehot’s world over 150 years ago and broker-dealers today. Reading Bagehot, we enter a world where capital market bonds are not yet the focal point of trading and prices, as they would come to be in the 20th century. Instead, the focus of attention is the private, real bills market, which domestic manufacturers tap as a source of working capital, and which traders worldwide tap to finance the movement of tradable goods. It is a market in short-term private debt, typically collateralized by tradable goods, quite different from our 20th century market in long-term debt (see [Mehrling et al, 2013](#)). Similarly, repos in today’s financial system are also about the provision of working capital by broker-dealers to portfolio managers, much like real bills provided working capital for manufacturers and merchants in Bagehot’s world (see [Pozsar, 2014](#)).

The conceptual link between repo and the provision of working capital is clear through the observation that just as working capital refers to the short-term funding of real economy transactions with an aim to satisfy household and business consumers by producing and delivering real goods, repos effectively fund the working capital needs of levered bond portfolios in order to fund short-term financial economy transactions, that is trades, in the form of levered bets on the direction of interest rates, foreign exchange rates and credit spreads with an aim to satisfy retail and institutional investors’ wealth aspirations by delivering financial goods in the form of excess return (either in the form of pure alphas, or as the above sections imply, mostly leverage-enhanced betas).

Closely related, one might argue that the key reason behind this apparent shift in finance away from funding real economy transactions and toward funding financial economy transactions – as evident from the increased provision of working capital to asset managers as opposed to traders and manufacturers – may be secular changes in the mix of “things” that need financing over time: underwriting global trade and manufacture in Bagehot’s world (real bills); underwriting victory and freedom during World Wars I and II (Treasury securities); underwriting the American dream and the consumer middle-class after WWII (consumer credit and mortgage loans and later ABS and RMBS); and more recently, the underwriting of equity-like returns with bond-like volatility for pension funds and other real money accounts amidst a proliferation of structural asset-liability mismatches by using securities financing transactions and derivatives as techniques to bridge the gap between rosy return expectations and the realities of a down-drift in yields on safe, long-term assets (see Figure 18).¹¹

In this sense, securities financing is a conceptually under-appreciated “fourth” form of finance alongside the three categories of bank credit identified by Adair Turner (see [Turner](#), 2013). These are [1] loans to finance productive investments and ideas; [2] the purchase of existing assets (mainly residential real estate); and [3] the smoothing of life-cycle consumption (consumer credit). Along this line, we may think of securities financing as a very distinct, fourth type of credit, one that gained prominence with the proliferation of structural asset-liability mismatches at pension funds and other real money accounts, and one that is a natural extension of the demographic cycle of advanced economies where financing needs shift from funding the construction and purchase of homes and consumption (cash flows from borrowing activities as a supplement to wages and salaries), to the funding of pension portfolios so that the cash flows they generate are in line with the cash flows promised to retirees (cash flows from investment portfolios as a substitute to wages and salaries).

Part III – Perception Gaps

Although no precise measures are available, the presence of leverage among hedge funds with credit and fixed income strategies has been recognized since the LTCM crisis (see Figure 21), as is leverage in separate accounts in the asset management complex (which are unmeasured due to data gaps).

While hedge funds and separate accounts are allowed to use leverage liberally – in fact, leverage is the *sine qua non* of these investment vehicles – it is widely underappreciated that bond mutual funds that are typically thought of as unlevered and long-only also have considerable room to use leverage.

The extent to which this room to use leverage is utilized is up to bond portfolio managers to decide, and it is not uncommon for the largest bond funds to maximize the leverage they may bear in their portfolio within the limits allowed by the Investment Company Act of 1940, and the SEC’s interpretation of the portfolio leverage and concentration incurred through the use of derivatives.¹²

¹¹ Private equity – the purchase of existing assets (mostly corporations, infrastructure and real estate) financed with a combination of long-term debt and equity – are a variation on the same theme. But since the topic of this paper is the sources and uses of short-term funding (that is, securities financing and more broadly shadow banking), term-funded private equity deals are excluded from the discussion of vehicles that promise equity-like returns with bond-like volatility.

¹² Section 18(f)(1) of the Investment Company Act (see [here](#)) restricts the ability of mutual funds to incur leverage by limiting the funds’ borrowing to 300 percent of asset coverage (a maximum degree of leverage of 1/300, that is 30%). There are no hard caps on the amount of leverage that 40 Act funds may incur through the use of derivatives; leverage through derivatives is limited only by the SEC’s interpretation of a portfolio’s leverage and concentration incurred.

However, the creep of leverage into what are traditionally thought of as long-only bond funds was missed by the mainstream economics literature and textbooks entirely. For example, recent works that identify asset managers as the core intermediaries behind the “second phase of global liquidity” focus solely on indirect forms of leverage (FX mismatches) embedded in bond portfolios through holdings of dollar-denominated emerging market sovereign and corporate bonds (see [Shin](#), 2013).

Other works state even more explicitly the widely-held assumption that fixed income mutual funds are unlevered, and analyze episodes of market volatility induced by redemptions without any regard to how direct forms of leverage embedded in fixed income mutual funds may amplify volatility during periods of rising redemptions (see for example [Feroi, Kashyap, Schoenholtz and Shin](#), 2014, Chapter 1 of the International Monetary Fund’s [October 2014 Global Financial Stability Report](#), Chapter 6 of the BIS’ [84th Annual Report](#), and Brown, Dattels and Frieda, 2014 (forthcoming)).

But all of these views sit uncomfortably with the hard evidence presented above, and recent revelations about “perceived” alphas (see [Gross](#), 2014b) and price action in the interest rate derivative markets amidst soaring redemptions from the largest bond portfolio in the global financial ecosystem – the PIMCO Total Return Fund (see [Mackenzie and Meyer](#), 2014).¹³ More concretely, a look at the portfolio of this specific fund provides good examples of the forms of leverage discussed above. Figure 22 shows the balance sheet of the fund as of March 31, 2014 based on SEC filings.

Section [1] shows the cash pool segment of the fund. Note how the composition of the fund’s cash sub-portfolio corresponds to the four types of money discussed in Part I, and how the allocation weights reflect the “do not lose” mandate of cash pools – shadow money in the form of Treasury repos and shares in PIMCO’s central liquidity fund dominate. Just over 10% of the bond fund is a cash pool – a hint at the rising prominence of the phenomenon of reverse maturity transformation (see [Pozsar and Singh](#), 2011), whereby funds with long-term mandates invest an increasing share of their assets in “cash” due to the increased prominence of derivative overlay investment strategies (also note that PIMCO’s treatment of net offsets related to derivatives prior to 9/30/14 suggest that the fund’s cash pool segment is larger than what is in Figure 22 based on the fund’s annual report).¹⁴

Section [2] shows the derivatives segment of the fund. Here, we cannot tell what share of derivatives is a part of the derivative overlay investments mentioned above (where exposures to duration, credit and FX risks are built by combining public and shadow money claims with derivatives in a single portfolio), and what share of derivatives is a part of hedges, but presumably both uses are present.

Section [3] shows the securities financing segment of the fund. Here, note the use of repo, securities lending and shorts as sources of leverage for the fund, and in particular, note the massive divergence

¹³ “[Gross triggers sell-off in interest rate derivatives](#)” by Michael Mackenzie and Gregory Meyer, *FT*, October 5, 2014.

¹⁴ See https://investments.pimco.com/Products/MutualFunds/Pages/Sector_Diversification_Breakdown.aspx: “When we hold an exposure via derivatives, we report the exposure the instruments give the Fund to a specific sector of the market. For example, if we buy a U.S. Treasury futures contract on a notional amount equal to 5% of the Fund’s market value, we report a 5% allocation to government bonds. However, given that the 5% represents the Fund’s economic exposure to governments rather than an allocation of capital (since the purchase of futures only requires a small outlay of cash to cover margin requirements), we also list an offset of -5% to prevent the sum of all sectors from exceeding 100%. These changes [...] affect where these offsets are shown on sector allocation reports. In the past, net offset related to derivatives were included in the Net Cash Equivalents category, which included cash and other short term investments together with the offsets associated with such derivative exposure. [...] Starting with the August 2014 report we will break this information into two categories: Cash Equivalents and Net Offset Related to Derivatives.”

between the fund's reported, quarter-end level of repo leverage, and the more than five-times larger, average level of repo leverage during the quarter (footnote 2 on page 24 of the fund's [annual report](#)).

Section [4] shows the fund's long positions in various types of bonds. This is what the canonical view assumes about what bond fund portfolios look like, but as our discussion and the examples above demonstrate, this is an increasingly outdated view of how modern asset management works (also see footnote 15, which notes that some of these exposures may be cash overlay investments).

Figure 23 shows how the U.S. Financial Accounts portray the balance sheet of bond mutual funds (see table [L.121](#)), versus the balance sheet of the PIMCO Total Return Fund as shown in Figure 22. Note the absence of any hints of leverage in the former and the presence of leverage in the latter, giving the term net asset value (that is assets net of leverage) a whole new meaning. Although the amount of leverage shown in Figure 23 is modest, one should be mindful of the fact that just like broker-dealers, bond mutual funds use a lot more leverage during the quarter than at quarter ends. As such, the above numbers likely demonstrate only the tip of the iceberg in terms of the leverage embedded in "long-only" mutual funds, and provide useful guidance as to the level of leverage one might expect in separate accounts and credit and fixed income arbitrage hedge funds more generally.

Here, also note how sections [1] through [3] of the Total Return Fund's balance sheet resemble features of the cash and bond portfolios on the two sides of money and risk dealers in Figure 20, and how deeply integrated the Fund is with the dealer ecosystem – that is, the shadow banking system – both as a cash pool provider of funding to money dealers, and a leverage-taker from money dealers, as well as a seller and buyer of risk exposures using derivatives through risk dealers.

More broadly, the above example demonstrates the evolution of the traditional core product of the asset management industry – long-only, relative-return funds – as it came under pressure from two directions: from hedge funds, offering absolute return strategies, and from passive index-replication products in the form of low-cost exchange traded funds (ETFs). Core-satellite investment mandates became the trend, with hedge funds providing alpha and index-replication vehicles delivering beta at low cost. Traditional asset managers responded to this challenge a number of ways: some by launching their own, internal hedge funds, and some by incorporating into their core products many of the alternative investment techniques used by the hedge funds. These industry trends were the sources of competitive push that drove the above-mentioned creep of leverage into the industry's traditional, long-only, relative-return bond funds (and hence the rise of levered betas), all designed to stem the flow of assets to the hedge fund competition and command higher fees as the profitability of traditional core products was squeezed (see Bank of New York, 2011 as well as [Haldane](#), 2014).

Figure 24 shows a summary view of these three basic products of the asset management complex: pure, uncorrelated alphas on the left, low-cost, index-tracking betas on the right and their blend in the middle – leverage-enhanced betas which are also known as "smart betas" or "perceived alphas". As a rule of thumb, pure alpha and levered beta strategies heavily rely on dealer balance sheets, and are heavy users of wholesale funding intermediated through the shadow banking system. This points to deep, structural links between asset management and the shadow banking system (see Figure 25; also note that pure beta strategies are increasingly reliant on dealer balance sheets as well; for example a synthetic ETF can give exposure to the bond market using cash plus total return swaps).

Perhaps the key reasons why economists have missed the creep of leverage into the traditionally long-only world of fixed income mutual funds are the conceptual gaps in the way in which the U.S. Financial Accounts (formerly the Flow of Funds) depict the global financial ecosystem, and by extension, the limited mental map it gives to economists who use it to understand asset prices.

For example, up until recently, the U.S. Financial Accounts provided only net, not gross measures of repos, and practically still exclude securities lending activities. This is problematic for two reasons.

First, net repo only captures the volume of short-term funding raised by broker-dealers to fund their own securities inventories, but ignores the much larger gross volume of funding that broker-dealers intermediate – as money dealers – from cash pools to levered bond portfolios. Conceptually, levered bond portfolios funded by broker-dealers across the entire asset management complex are economic equivalents of global banks' wholesale-funded bond portfolios, and the portion of broker-dealers' fixed income inventories that are funded in the short-term repo markets. All three represent sources of levered bids for fixed income securities ranging from Treasuries to mortgages and other bonds, and balance sheet capacity for the provision of credit to the real economy (see Figure 26). Yet, they are not included in leading models of leverage and asset prices (see [Adrian, Moench and Shin](#), 2014), which focus on net repos, that is, funding raised by broker-dealers' to fund their own inventories: gross versus net flows matter not only in the context of international capital flows and asset prices (see [Cecchetti](#), 2011 and [Shin](#), 2012) but also in the context of domestic fund flows and asset prices.

Figure 27 shows the limited information we have about the types of entities that absorb the volume of securities financing extended by broker-dealers: for example, we only have data on the size of M-REITs, which according to the data from the U.S. Financial Accounts (see table [L.127](#)) currently make up less than 15% of the levered bond universe outside of global banks' portfolios and dealers' securities inventories. Outside of mortgage REITs, the U.S. Financial Accounts provides no hints that other hedge funds, mutual funds (such as the PIMCO total return fund) and separate accounts (run by asset managers for real money investors) are large consumers of dealer balance sheets.

Second, the exclusion of securities lending is problematic as bond funds (and especially the largest ones) may use securities lending transactions to mask transactions that are economically repos. Indications that this is indeed the case include pieces of anecdotal evidence, which stipulate that because Master Securities Loan Agreements (MSLA), unlike Master Repurchase Agreements, favor the lender of securities over the dealer,¹⁵ some of the largest asset managers prefer to structure repos as security loans and execute them under MSLAs, as well as the fact that the bulk of securities lending transactions involve low intrinsic value Treasury debt and agency mortgage-backed securities (see [Keane](#), 2013). The latter implies that some securities lending transactions may be motivated by search for yield through cash collateral reinvestment, as opposed to harvesting the intrinsic value of securities that trade special, coupled with conservative cash collateral reinvestments (this was certainly the case before the Crisis (see [Citi](#), 2014), but this trend has moderated since ((see Part IV)).

From a macro-financial perspective, it is crucial to get a firm handle on who broker-dealers are funding through their financing operations, and by extension, the aggregate volume of levered bids they finance for fixed income securities throughout the asset management complex. This is because

¹⁵ The use of Master Securities Forward Agreements (especially those that enable an asset manager to do forward trades against specific securities) further muddles the line between the equivalence of repos, security loans and forwards.

levered bids may have been playing an important role in compressing the Treasury term premium and spreads on risk assets before the Crisis. However, the way the U.S. Financial Accounts are presently organized as far as broker-dealers and asset managers are concerned do not suggest that levered bids for Treasuries and other bonds have a sizeable footprint in the broader ecosystem.

Looking at the holders of U.S. Treasury securities in table [L.209](#) would leave one with the impression that the largest levered investors in U.S. Treasuries are global banks and broker-dealers, while missing the footprint of the much larger group of levered bond investors in the asset management complex, as implied by the gross repo numbers of the [FR2004](#) survey as a proxy for the volume of balance sheet capacity extended by broker-dealers to the managers of total and absolute return bond funds, risk parity funds, hedge funds and separate accounts to name a few (mortgage and credit assets would involve a broader set of bond investors such as mortgage REITs).

This omission could in turn have important implications for how we measure assets prices, as the idea of the secular rise of levered bids for fixed income securities from levered bond portfolios could be a powerful alternative to the narrative that Treasury term premium and spreads were compressed by a global savings glut (see [Bernanke](#), 2005) or a global banking glut (see [Shin](#), 2011).

Figure 28 shows that the pre-crisis decline in the Treasury term premium (Greenspan's conundrum) coincides not only with an increase in FX reserves (Bernanke's savings glut), but also with the secular increase in the volume of securities financing transactions, whereby matched-book money dealers became the financiers of massive volumes of leveraged bids for fixed income securities by intermediating ever-larger amounts of cash from cash pools to an ever-larger number of leveraged fixed income investors. This we may as well interpret as a "leveraged bids glut" and as a supplement to Hyun Shin's global banking glut hypothesis: whereas Shin's banking glut focuses specifically on European banks' involvement in funding U.S. residential mortgages through the Eurodollar funding market, the "leveraged bids glut" focuses on U.S.-based primary dealers' involvement in funding Treasuries and other fixed income securities for asset managers in onshore repo funding markets.

Although more research is needed in this area, the idea that leveraged bids for fixed income securities compressed the Treasury term premium appears to be a compelling alternative to than the idea that accumulating FX reserves compressed them. This is because reserve managers are funded investors beset with structural asset-liability mismatches due to sterilization costs, which if anything should incent them to underpay and not overpay for Treasury securities. In contrast, the reasons why levered fixed income investors would overpay for Treasury securities are more obvious.

Data collection efforts by the Securities and Exchange Commission (SEC), the Federal Reserve and the Office of Financial Research (via Form PF and the bilateral repo pilot survey (see [Berner](#), 2014)) will help quantify these forms of leverage and their impact on asset prices. But equally important, there is much to be gained from systemically harvesting all publicly available data (from SEC filings) on the leverage embedded in what are commonly perceived as unlevered 40 Act bond mutual funds.

Part IV – Secular Stagnation (and How It Relates to Shadow Banking)

This part of the paper explains how the secular rise of cash pools searching for safety, and the secular rise of levered bond portfolios searching for yield have been driven by macro imbalances both global and local, present and future (see [Pozsar](#), 2014), and why we may interpret the

phenomenon of shadow banking as the financial economy reflection of the same real economy imbalances that are behind the recently revived concept of secular stagnation (see [Summers](#), 2014).

Figure 29 lists these macro imbalances on two sides of the dealer ecosystem. Imbalances behind the rise of cash pools are listed on the right-hand side of the figure (items [1] – [2]) and have to do with imbalances in the distribution of present incomes, and imbalances behind the rise of levered bond portfolios are listed on the left-hand side (items [3] – [4] and [5] on the right-hand side) and have to do with a proliferation of structural asset-liability mismatches, that is imbalances in future promises.

Item [1] notes the secular rise of managed FX regimes vis-à-vis the U.S. dollar in China, southeast Asia and among oil exporters as the key reason behind the accumulation of massive FX reserves on the back of persistent current account surpluses since China’s integration into the world trading system in 2000 (also known as Bretton Woods II, see [Dooley, Folkerts-Landau and Garber](#), 2014). The liquidity tranche of FX reserves is the first of three cash pools identified in Part I of the paper, and we can interpret the growth in FX reserves as a reflection of imbalances in the distribution of present incomes between current account surplus and deficit countries accumulated over time.¹⁶

Item [2] notes the secular rise of corporate profit margins as a share of U.S. national income at the expense of stagnant wages (hence the shorthand “capital vs. labor”) as the dominant reason behind the rise of free cash flows and corporate cash balances – the second of three cash pools identified in Part I of the paper. We can interpret the growth in corporate cash pools as a reflection of imbalances in the distribution of present incomes between capital and labor accumulated over time.

Although more analysis is needed in this area, one can identify a range of secular developments that explain why corporate cash balances have been rising since 2000. These include globalization, demographics, technological progress, increased sophistication at arbitraging of global tax regimes, and what has been referred to as the rise of the weightless economy (see for example Wilmot, 2014).

First, with regards to globalization, the integration of China and other emerging market economies into the world labor market has been widely recognized as the main driver behind stagnant real wages in advanced economies (see [Rajan](#), 2011), and by extension, greater corporate profit margins.

Second, with regards to demographics and technology, “slower population and possibly technological growth means a reduction in the demand for new capital goods to equip new workers” and “lower priced capital goods [and especially information technology equipment] means that a given level of [corporate cash flow] can purchase much more capital than was previously the case” (see [Summers](#), 2014). In sum, these developments suggest that corporations are spending less of their cash inflows on investments due to secular, demographic headwinds, and whatever investments they decide to spend on (mostly to enhance the productivity of existing processes, see [Thiel](#), 2014) cost fewer and fewer nominal dollars due to secular, technological tailwinds blown by Moore’s law.

Third, with regards to arbitrage, increasingly sophisticated tax avoidance strategies by global corporations have reduced corporate tax payments and on the flipside tax receipts for governments

¹⁶ The share of countries under a freely floating FX arrangement vis-à-vis the U.S. dollar has declined from over 45% of world GDP and world exports in 2000 to 35% in 2007 (see [Eichengreen et al](#), 2011). On FX reserve accumulation contributing to the rise of short-term assets held by reserve managers see [Pozsar](#), 2011 and [McCauley and Rigaudy](#), 2011.

(see G20's [Brisbane Communiqué](#), the G20/OECD [Base Erosion and Profit Shifting Action Plan](#), the recent shutting of the "[Double Irish](#)" corporate tax loophole, and crackdown on [tax inversions](#)).

Fourth, an additional reason why corporate profits, cash flows, and – over time – cash pools have been on a secular uptrend is that today's iconic, cutting-edge, technology, software and social media companies need little if any capital to expand, whereas iconic, cutting edge companies of yore needed to go to the market to support expansion (also [Summers](#), 2014) – in short, GM needed to build more factories to sell more cars, but Microsoft can sell more code at little to no additional cost.

These factors as the secular macro drivers behind the rise of the two largest types of cash pools – the liquidity tranche of FX reserves and corporate cash pools – are identical with those cited by [Summers](#), 2014 as to why interest rates may have drifted substantially lower in recent decades.

What this implies is that imbalances in the distribution of present incomes from those with high propensities to spend and invest to those with low propensities to spend and invest – whether in the context of current account surplus *vs.* deficit nations, capital *vs.* labor, or the 1% *vs.* the 99% – and the resulting excess savings over investments at the macro level, may have been exerting a downward pressure on interest rates, may have been fanning asset price bubbles, and may have been shackling the U.S economy in a state of secular stagnation – unable to achieve full employment and satisfactory growth in a financially stable manner – since well before the Great Financial Crisis.

Indeed, the thesis of secular stagnation is about much more than just the present and the future – that is, what the above trends mean for the economy's current pace of growth relative it's potential, and the pace of potential growth going forward. It is also about the re-evaluation of U.S. economic performance during the early 2000s up to the Great Financial Crisis. As noted by [Summers](#), 2014:

“Unfortunately, it appears that the difficulty that has arisen in recent years in achieving adequate growth has been present for a long time, but has been masked by unsustainable finances. Here it is instructive to consider the performance of the U.S. [...] economy prior to the onset of the financial crisis in 2007. [...] It is certainly fair to say that growth was adequate – perhaps even good – during the 2003-2007 period. However, it would not be right to say either that growth was spectacular or that the economy was overheating during this period. And yet this was the time of vast erosion of credit standards, the biggest housing bubble in a century, the emergence of substantial budget deficits, [...] lax monetary and regulatory policies. Imagine that U.S. credit standards had been maintained, that housing had not turned into a bubble, and that fiscal and monetary policy had not been stimulative. In all likelihood, output growth would have been manifestly inadequate because of insufficient demand. Prior to 2003, the economy was in the throes of the 2001 downturn, and prior to that it was being driven by the internet and stock market bubbles of the late 1990s. So it has been close to 20 years since the U.S. economy grew at a healthy pace supported by sustainable finance.”

Summers goes on to note three ways in which low interest rates may undermine financial stability: “[T]hey increase risk taking as investors reach for yield, promote irresponsible lending as coupon obligations become very low and easy to meet, and make Ponzi financial structures more attractive as interest rates look low relative to expected growth rates [...] developments that were surely at work during the 2003-2007 period [and are increasingly present today]” (also see [Summers](#), 2014).¹⁷

¹⁷ Summers cites two additional factors that may have contributed to the decline in the full employment interest rate. These are increased frictions in financial intermediation and greater risk-aversion following the Great Financial Crisis, driven by increased regulation, debt overhangs and increased uncertainty discouraging borrowings and investments.

But in light of Parts I and II of the paper, we could add two more sources of financial stability risk: the first has to do with the portfolio preferences of cash pools discussed in Part I of the paper; and the second with the structural as opposed to cyclical reasons behind search for yield – namely, demographic factors (an ageing population) driving the stock of pension promises higher, long-term interest rates lower and – as a combination of the two – asset-liability mismatches wider, making them the ultimate, structural drivers of search for yield in the financial ecosystem (see [Pozsar, 2013](#)).

With regards to the first, to the extent that savings accumulate in the hands of investors – such as FX reserve managers and corporate treasurers – that have a sizeable appetite for safe, short-term assets (corporate treasurers seek almost exclusively short-term assets, while FX reserve managers seek sizeable volumes of short-term assets through the liquidity tranche of their portfolios), the provision of shadow money claims by the global financial ecosystem as substitutes for Treasury bills that are scarce, and insured bank deposits that are off-limits also poses threats to financial stability as shadow money claims are not supported by official backstops and are hence prone to runs.

In this sense, imbalances in the distribution of present incomes between nations and factors of production (the heart of the secular stagnation thesis), wholesale funding, and the demand for and supply of shadow money claims are closely interlinked. Moreover, to the extent that the manufacture of quasi Treasury bills through short-term repos backed by longer-term Treasuries may depress the yield on Treasury securities through levered bids (Figure 28), cash pools' demand for safe, short-term assets may have been an additional factor behind the secular decline of nominal interest rates.

With regards to the second, reach for yield is not necessarily related to the absolute level of interest rates, but rather the level of interest rates relative to the level of expected returns and discount rates.

Reach for yield is omnipresent in a financial system where investors are hardwired to beat their benchmarks, but reach for yield intensifies as actual yields drift farther and farther away from the return targets of investors with fixed liabilities. This drift may have secular or cyclical reasons behind it (that is, its drivers may be structural or policy driven), which means that reach for yield is more intense during periods when policy rates are kept low in order to stimulate economic activity.

But to amplify, reach for yield is not limited to periods of low policy rates; it's just that it's more intense during those periods. And as discussed in Part II, the key drivers behind structural (as opposed to cyclical) reach for yield have been accumulating pension promises and ever lower yields on safe, long-term assets – both due (in large part) to the same demographic reason, namely ageing.

Underfunded pensions represent risks to financial stability through their demand for levered investments that offer equity-like returns with bond-like volatility using leverage sourced via dealers.

Item [3] in Figure 29 notes underfunded pensions as the prime example of rising asset-liability mismatches in the financial ecosystem, and by extension, an ultimate source of reach for yield. Pension funds were one set of institutional investors that following the dot com bubble and subsequent decline in long-term interest rates drove the demand for products (such as the levered fixed income and/or credit mutual funds, hedge funds and separate accounts discussed in Part II), with a mandate to beat the benchmark and promise equity-like returns with bond-like volatility.

Figure 30 – another Mount Fuji chart (see [Geithner, 2014](#)) – shows the actuarial funding level of the largest public retirement systems in the U.S. (at the end of fiscal year 2012, systems in the survey that produced these numbers held assets of \$2.63 trillion and comprise about 85% of the entire state and local government retirement system community (see [Public Fund Survey, 2013](#))). Note the collapse of funding levels in the aftermath of the dot com bubble – the inflexion point that marks the start of the promotion of the above products, exploiting the growing gap between pension funds’ unchanged discount rate assumptions and ever lower yields on safe assets (see Figure 18).

Figure 31 shows pension funds’ rising holdings of alternative investments as vehicles that promise to generate equity-like returns with bond-like volatility. Here, also note that levered bond portfolios are present not only through pension funds’ increased allocations to alternative investments, but also implicitly through the use of levered separate accounts, liability-driven investment strategies, and the use of leverage by institutional-class mutual funds, all of which are captured by the survey as traditional, “long-only” fixed income investments (as such, looking only at allocations to alternative investments would somewhat understate the amount of leverage embedded in pension portfolios; the grey line in the figure [indicates](#) the presence of embedded leverage in fixed income allocations, but a precise measure of the amount of leverage present in fixed income allocations isn’t available).¹⁸

Figure 32 shows an elegant summary of all this, showing a strong positive correlation between the degree of public pension funds underfundedness and the degree of their allocation to risky assets, including alternatives (the greater the degree of pension funds’ underfundedness, the greater their allocation to alternative investments as implied by the size of the red bubbles (see [Caballero, 2013](#))).

Item [4] in Figure 29 notes the sterilization costs associated with fixed/managed exchange rate regimes and accumulating large volumes of FX reserves – another example of rising asset-liability mismatches in the financial ecosystem. This is because the bills issued to sterilize the exchange of foreign currency to domestic currency yield more than the average yield of the foreign bonds that FX reserves are held in, which is a fiscal cost (see Figure 18 again). To minimize these fiscal costs, reserve managers also allocate some of their portfolios to separate accounts that employ leverage.

In addition to reaching for yield through products offering levered betas, real money accounts also became more active in securities lending by lending from their portfolios securities held outright. Figure 33 shows the secular increase in the volume of securities lending by beneficial owners (such as mutual funds and retirement and pension funds, see the upper-left chart), and as our discussion in Part III suggests, some of these transactions are not necessarily motivated by harvesting the intrinsic value of securities that trade special or are in demand by short sellers, but rather the raising of cash collateral motivated by search for yield to enhance portfolio returns to get closer to discount rate assumptions and reduce fiscal costs as discussed in Part II (see Figure 18 again). This can be seen from the fact that about half of the volume of securities lent are low intrinsic value government

¹⁸ On the degree of [corporate](#) pension funds’ structural under-funded status see [Towers Watson, 2012](#), and on the degree of [state and local](#) pension funds’ structural under-funded status see [Novy-Marx and Rauh, 2013](#). On the secular rise of levered portfolios see the rise in hedge fund’s assets under management from less than \$50 billion in 1990 to \$500 billion in 2000 and \$2.25 trillion in 2012 (see [McKinsey Global Institute, 2007](#) and [HFR, 2012](#)). Finally, on the rise of pension funds’ and endowments’ increased allocation to hedge funds see the increase in hedge funds’ capital under management from pension funds and endowments rise from about 15% in the mid-1990s to 30% in the mid-2000s and nearly 35% as of March, 2012 (see [McKinsey Global Institute, 2007](#) and [FSA, 2012](#)), and U.S. pension funds’ allocations to alternative investment strategies doubling from 10% in 2002 to over 20% in 2012 (see [Towers Watson, 2012](#), pp. 31).

bonds (see the lower-left chart), which command very little in lending fees relative to high intrinsic value equities and corporate bonds (see the relative size of the green areas on the charts on the right), but for which revenues earned through cash collateral reinvestments point to relatively more aggressive reinvestment practices than those on high intrinsic value equities and corporate bonds.

Finally, item [5] of Figure 29 on the right-hand side notes the rising cash intensity of the modern asset management complex as a reflection of institutional investors' ever more intense search for yield. As noted above, this development has been driven by the rising prominence of securities lending and corresponding increase in cash collateral reinvestments, as well as the rise of derivative overlay investment strategies used by mutual funds and hedge funds as well as by separate accounts (the latter for the implementation of bespoke, liability-driven investments for pension funds).

In addition to the rising cash intensity of these investment strategies, the rise of cash pools within the asset management complex has also been exacerbated by the much documented increase in the concentration of the asset management industry (see [OFR](#), 2013, [Haldane](#), 2014 and [BIS](#), 2014).¹⁹

Given the centralized liquidity management of fund complexes, ever more savings being managed by ever fewer asset managers are yet another form of distributional imbalances, and a very real, yet under-appreciated source of systemic risk, as similar to the liquidity tranche of FX reserves and corporate treasurers, asset managers are important sources of demand for safe, short-term assets and hence structural drivers of the demand for maturity transformation in the wholesale funding market.

To recap, the proliferation of asset-liability mismatches across public pension funds (see Figure 30) and other real money accounts has been the main driver of the demand for investments offering equity-like returns with bond-like volatility, and drove the rise and institutionalization of alternative investment strategies such as hedge funds and the “creep” of leverage into traditional, long-only bond funds (see Figure 31). The more underfunded a real money account, the stronger its demand for equity-like returns with bond-like volatility (see Figure 32); for similar reasons real money accounts have also become active lenders of securities in order to supplement their portfolios' yield (see Figure 33). Broker-dealers are central to all this (see Figure 34): as matched-book money dealers, they provide the leverage to the bond portfolio managers that helps them engineer excess returns at low volatility for the real money accounts whose funds they manage, and fund all this leverage by tapping into deposit-averse cash pools in search for secured (repo) forms of money (see Figure 35).

Figure 36 provides a summary of the discussion above. It frames the global financial ecosystem as composed of four tribes of players, each with a clearly-defined mandate. Going from left to right, chief investment officers (CIOs) of real money accounts (from individual savers to pension funds, endowments, insurance companies and reserve managers) are mandated to “meet liabilities” – they seek equity-like returns with bond-like volatility. They do so by allocating more of their portfolios to levered bond portfolios (from hedge funds to mutual funds and separate accounts) that are mandated to “beat the benchmark” by offering equity-like returns with bond-like volatility through a combination of long-only, levered and synthetic exposures to credit, maturity and liquidity risks.

¹⁹ See for example [Asset management hits record level](#), FT, July 9, 2013 which notes that the asset management “industry is [increasingly] taking on winner-takes-all characteristics. The top 10 U.S. managers took almost two-thirds of all net new fund assets among managers with positive net flows in 2012 compared with 54 per cent in 2011”. Also see the OFR study on asset managers which notes: “economies of scale in portfolio management and administration [...] have increased industry concentration in recent years” (see [Asset Management and Financial Stability](#), OFR, 2013).

Cash pools, whose mandate is “do not lose” shun credit, maturity and liquidity risks and invest their cash balances with the sovereign, or on a collateralized (repo) or diversified basis (money funds). Finally, cash pools are the products of decisions taken by CEOs at corporate and sovereign levels whose mandate from shareholders and voters is to “grow” their profits and economies, respectively.

As the above discussion implies, we may interpret shadow banking (that is, the ecosystem of broker-dealers flanked by cash and bond portfolio managers) as the financial economy reflection of the very same real economy imbalances that are behind the recently revived concept of secular stagnation.

After all, cash pools searching for quasi Treasury bills in the form of repos are a reflection of the same macro drivers that are behind the savings-investment imbalances that may have been responsible for driving interest rates ever lower in recent decades (one cornerstone of the secular stagnation thesis), and ever lower interest rates (partly due to demographic headwinds – another cornerstone of the secular stagnation thesis) are the main drivers of levered bond portfolios across the asset management complex soaking up ever more wholesale funding intermediated by broker-dealers as a key input to generate equity-like returns with bond-like volatility for pension funds as well as other real money accounts such as endowments, insurance companies and reserve managers.

Finally, a note on shadow banking as a reflection of global imbalances versus financial globalization (see [Mehrling, 2011](#)). As noted by Mehrling in “[Financial Globalization versus the Nation State](#)”:

“At its core, [the crisis of the shadow banking system] is really about financial globalization. Both words are important. When I say globalization I do not mean primarily trade in goods and services, but rather the integration of previously national money markets and capital markets. Securities markets are increasingly global as pools of investable capital seek out the highest risk-adjusted return, on individual investments but also on diversified portfolios of investments from around the world. And money markets are also global, as national borrowers who seek more funds than domestic lenders are offering inevitably find what they need in global funding markets, especially dollar funding markets. Financial globalization has created the modern world, and it is being tested to the core by the current crisis.”

Undoubtedly.

But, it is also important to appreciate the many imbalances of the modern, globalized world that financial globalization helped create. This is because the examples above all demonstrate that imbalances (whether between current account surplus versus deficit countries, capital versus labor, the 1% versus the 99% or a few large versus many small asset managers) may well have contributed to the deepening of the structural linkages (perhaps even reflexively, see [Soros, 2003](#)) between the dollar-based money and capital markets that helped create the modern, globalized world we live in.

Part V – Policy Dimensions

The macro view of the dealer ecosystem presented in Figure 36 suggests that there are at least three possible entry points for policymakers to manage the financial system and enhance its stability. These are at the G-SIB level, the asset manager level and the global macro level (see Figure 37).

First, reforming the G-SIBs to date focused on re-shaping market-based finance through the re-engineering of G-SIB’s balance sheets in terms of [1] the minimum amount and quality of the capital and liquidity G-SIBs must hold; [2] the maximum extent to which they may rely on short-term,

wholesale funding; and [3] the maximum extent to which they can be leveraged on a gross basis. The result of these reforms is a set of G-SIBs that is fortified (TLAC), stabilized (NSFR), liquefied (LCR) and cut down to size (SLR), but on the flipside a financial system that is less liquid than it used to be as new capital, funding, liquidity and leverage rules constrain market-making (see [BIS](#), 2014).

Recall our discussion of the centrality of matched-book money and risk dealing in Part II, which argued that dealers are more than brokers. They are not “mere” matchmakers, but entities that are willing to absorb temporary imbalances in order flows on their balance sheet – by willing to go long when the market wants to go short, and short when the market wants to go long. The result is inventories (of money market exposures, securities and derivative positions), sometimes long and sometimes short, depending on the direction of order flows. In essence, it is this elasticity of broker-dealers’ balance sheets and broker-dealers’ willingness and ability to make two-way markets and intermediate the resulting flows of cash and securities on their balance sheets that is the “grease” behind liquid markets. By extension, liquid markets are not some ephemeral concept, but something that is quite tangible and visible on the balance sheet of broker-dealers – large volumes of matched-book securities financing transactions and elastic inventories are market-liquidity, and the reason why market participants are able to buy and sell in large volumes without affecting prices by much.

In this sense, one can interpret the G20/FSB regulatory reform agenda to date as a desire to find a better balance between the economic benefits of deep and liquid markets, and the financial stability risks inherent in the (gross) balance sheet intensity of the provision of deep and liquid markets.

Second, asset managers. Reduced market liquidity is the key reason behind the regulatory attention shifting beyond banks, dealers, and money funds and toward asset managers in search for systemic risks. Over time, regulatory focus here needs to coalesce around two key areas of concern.

On the one hand, changes in the mix of investment funds that are in the business of absorbing the money demand of cash pools and the mix of public versus private money market instruments they hold: an area of great importance in the wake of the SEC’s reform of prime money market funds.

On the other hand, the extent to which leverage in all its funded and unfunded forms of credit, maturity, liquidity and FX mismatches is present in asset management on the balance sheets of investment funds, as well as changes in the instrumentality and institutional sources of this leverage.

All of this attention is fine and needed (especially given the reduced liquidity of secondary markets), but we must ask the question of what good is it if we were to locate and then constrain the leverage used by mandates across the broader asset management complex to “beat the benchmark,” without addressing the ultimate sources of search for yield: namely, the proliferation of asset-liability mismatches among real money investors in search for equity-like returns with bond-like volatility.

Similarly, what good is it if we were to locate and quantify the footprint of institutional cash pools and then frustrate their “do not lose” mandates by driving them away from dealers and money funds, without addressing the ultimate source of the growth of institutional demand for shadow money claims: global imbalances and the inelastic supply of public forms of money.

We would only be shifting the problems of leverage and private money around, not solving them. This leads to the third entry point: reforming the ecosystem that banks and asset managers inhabit.

Part IV discussed the extent to which institutional cash pools are reflections of imbalances in the distribution of present incomes between current account surplus versus deficit countries and capital versus labor, and the extent to which these imbalances were driven by the “growth” mandates of CEOs: pressures to generate growth via exports and jobs at the level of emerging market sovereign CEOs driving the growth of FX reserves, and pressures to grow market share, profits and share prices at the level of advanced economy corporate CEOs driving the rise of corporate cash pools.

It also discussed how the proliferation of structural asset-liability mismatches among real money investors are a reflection of imbalances in future promises as seen in the gap between pension funds’ funded status, discount rates and rising number of pensioners, and the secular decline in real yields; and how CIOs’ “meet liabilities” mandate drove demand for levered investments more generally.

And it argued that the push of the “wall of money” coming from cash rich, but safety poor cash pools, and the pull of “search for yield” coming from securities rich, but return poor real money accounts found one another at the intersection of money and capital markets through the balance sheet of broker-dealers. The secular increase in cash pools’ money demand got absorbed through the secular expansion of broker-dealers’ repo liabilities, and the secular increase in search for yield got financed through the symmetric expansion of broker-dealers’ reverse repo assets. Broker-dealers emerged as giant intermediaries of cash versus securities and vice versa, with their balance sheet growing from \$2 trillion in 2000 to a peak of \$5 trillion by 2008 and around \$2.5 trillion today.

In this sense, we can interpret the secular rise of broker-dealers as matched-book money dealers as a reflection of and rational response to the secular changes in the financial ecosystem around them.

This increase in the provision of private shadow money, and on the flipside, securities financing, became the hallmarks of finance over the past two decades. But their interpretation as “casino” banking (or “finance for finance’s sake”) missed the bigger-picture role played by broker-dealers in the financial ecosystem: the provision of safe, short-term assets for the safekeeping of cash pools that have outgrown the official safety net and had only minimal access to public money, and the provision of levered betas to help real money accounts reduce structural asset-liability mismatches.

And from this perspective, it is easy to see the essence of the third policy approach: the re-shaping of the ecosystem that G-SIBs and asset managers inhabit by aiming to eliminate (or at least mitigate) imbalances in present incomes and future promises – the drivers of cash pools and private money, and search for equity-like returns with bond-like volatility via levered bond portfolios, respectively.

A somewhat extreme analogy to an obese person is helpful to frame the basic idea: if banking reform and weeding leverage out of asset management are equivalents to bariatric surgery, reforming the broader ecosystem would be the equivalent of a new diet and exercise regime for the patient.

Just imagine a world where exchange rates would be freely floating and the stock of reserves would revert back to past benchmarks of levels sufficient to cover short-term foreign trade and debt bills. Reserves over and above this amount would be distributed among households equally. Furthermore, imagine a world where idle corporate cash pools would be taxed and distributed among households.

Both scenarios point to a world where the volume of wholesale funding would be much diminished. Instead of facing an ecosystem that is increasingly dominated by a relatively few, very large, uninsured and hence finicky and run-prone cash pools, we would be facing an ecosystem that is dominated by a large number of small, insured and hence stable retail depositors. Run-prone wholesale funding would be converted into stable retail funding, the money market would shrink in size and the instrumentality of intermediaries would shift away from repos to insured deposits.

These examples highlight the financial stability risks inherent in income inequality, whether in the context of current account surplus *vs.* deficit countries, capital *vs.* labor or the 1% *vs.* the 99%. And they also show how redistributive policies – including global currency and corporate tax reforms – may help enhance financial stability. The benefits of redistributive policies are usually looked at from a demand management perspective (see [Summers, 2014](#)), but their financial stability benefits through their impact on the size of wholesale funding markets are also important to appreciate.

Similarly, imagine a world where pension promises are renegotiated and retirement ages are raised. All of a sudden, the problem of underfunded pensions would be dealt with, and structural asset-liability mismatches would disappear. This would reduce search for yield and the peddling of investment strategies that promise equity-like returns with bond-like volatility. It would lead to a decline in the demand for levered betas and leverage across the broader asset management complex.

Finally, imagine the combined impact that redistributive policies and renegotiated pension promises would have on growth both “today” and “tomorrow” – more spending and hence an improvement in cyclical growth today, and more labor and hence an improvement in secular (that is potential) growth prospects going forward. And whatever asset-liability mismatches would remain, they would be more manageable due to a structural shift up in the Treasury curve on the back of faster growth.

All this would mean much reduced demand for securities financing and derivatives in investment management and hence a more stable financial system that is closer to the textbook image of banks that take deposits and make loans and finance real as opposed to financial economy transactions.

Of course, these thought experiments would be tough to implement politically both at the local and at the G20 level. But they are worth pondering about to appreciate the broader context in which the debate about managing the risks of shadow banking and financial stability should take place.

Other than the politically hard choices involved in reforming the global financial ecosystem, what else could be done? There are two options: one is the concept of dealer of last resort (DoLR), and the other the provision of more public money by governments. Far from being abstract ideas, both are being implemented as we speak – the idea of dealer of last resort by the Bank of England, and the idea of more public money by the Federal Reserve. Appreciating the opposite directions the two central banks are taking is important as they draw the contours of two different financial systems.

As shown on Figure 37, DoLR essentially provides liquidity insurance for dealers (directly) and to the ecosystem of cash and bond portfolio managers around them (indirectly). In essence, the announcement of the Bank of England on November 5th, 2014 that it widened access to its Sterling Monetary Framework to accept dealers and central counterparties amounts to updating Bagehot for the 21st century – backstopping the apparatus of working capital provision in the modern asset

management complex that Part II described as analogous to Bagehot's real bills world of yore. The carrot of DoLR came in exchange for the sticks financial reform enacted since the financial crisis.

Moreover, the BoE's announcement applies not only to the sterling money market, but also the Eurodollar money market. This is because the Bank's U.S. dollar operations are also governed by the Sterling Monetary Framework (see the BoE's [Market Notice](#) on USD Repo Operations from November 5th), which coupled with the October 31, 2013 [announcement](#) by the Bank of Canada, the Bank of England, the Bank of Japan, the ECB, the Federal Reserve, and the Swiss National Bank that their temporary bilateral liquidity swap arrangements are being converted to standing arrangements (which constitute a network of bilateral swap lines among the six central banks and allow for the provision of liquidity in each jurisdiction in any of the five currencies foreign to that jurisdiction) means the BoE also backstops Eurodollar funding (repo) and derivative (swap) markets.

Appreciating the implications of the dealer of last resort announcement for the Eurodollar market is important, as it amounts to the first formal backstop of the global dollar funding markets in the history of the dollar as the global reserve currency: money market funding of capital market lending denominated in dollars and transacted offshore (mostly in London) is now effectively insured against liquidity crises. In other words, the international portion of the shadow banking system is now insured against liquidity "bumps" in wholesale funding (repo) and risk transfer (swap) markets. Thus, we may remove the word shadow when referring to the offshore portion of shadow banking.

The Bank of England is now the dealer of last resort to the Eurodollar money and capital markets – backstopping dollar-denominated money market funding of capital market lending outside the U.S. – the international version of what the Federal Reserve could be for markets onshore in the U.S.

In contrast, policy discourse in the U.S. is firmly in the direction of crowding out private money with the issuance of more public money. It focuses less on how to make the provision of private money safer through the provision of liquidity insurance in exchange for financial reforms enacted since the crisis, and more on how to crowd out private money creation, chiefly by boosting the supply of public money claims. The two main mechanisms under consideration are boosting the issuance of short-term Treasury bills and the volume of overnight reverse repos (RRPs) offered by the Federal Reserve. Both alternatives would increase the role of the public sector in absorbing the money demand of cash pools, draw funding away from private intermediaries, and would thereby enhance financial stability (see [Greenwood, Hanson, Rudolph and Summers](#), 2014 and [Pozsar](#), 2011).

The options of both "dealer of last resort" and "more public money" are both workable. But the former lets the private sector internalize the gains from private money creation (and now with the "carrot" of liquidity insurance, albeit with more sands in the wheels (due to re-regulation)), while the latter socializes these gains. Socialized gains would show up in the form of reduced interest bills for the U.S. Treasury (by funding more of its debt on the short versus the long-end of the curve (here, think of the sovereign as a "bank")) and also through more remittances (that is, seigniorage revenues, or public "carry") from the Federal Reserve to the U.S. Treasury. Besides the taxpayer, the main beneficiaries of more public money would be cash pools, whose portfolios would include more truly riskless public money and less private money which are only riskless in good states of the world. The losers in this configuration are the matched-book money dealers and the bond portfolios who have heretofore intermediated and absorbed these large flows of cash *vs.* securities, using them to generate excess returns and to create safe, short-term assets for cash pools on the flipside.

Figure 38 shows how the increased provision of public money would absorb the money demand of cash pools and crowd out private money creation. The swapping of excess reserves for reverse repos and boosting the supply of Treasury bills (whether in a reserve neutral or reserve draining fashion (for the latter, see the TBAC recommendation to boost Treasury's cash balances from negligible amounts to \$500 billion)) would both lead to shrinking bank balance sheets (as reserves are swapped into RRP deposits flow out of banks to fund RRP counterparties such as money funds) as well as shrinking dealer balance sheets as more Treasury bills and RRP offer alternatives for money funds that are safer than dealer repos. And on the flipside, reduced matched-book repo volumes mean less funding for levered bond portfolios and fewer opportunities for lending low intrinsic value securities, both of which will reduce opportunities to deliver excess returns via levered betas for pension funds and other real money accounts that struggle with structural asset-liability mismatches.

These flows will be further amplified by two key developments on the regulatory front. First, the SEC's decision to require institutional-class prime money funds, but not government-only funds, to float their NAVs. This will lead to reallocations from prime to government-only funds. Second, the Supplementary Leverage Ratio (SLR), which will restrict broker-dealers' ability to be an elastic source of supply for shadow money claims via matched-book repos. The two are closely related as for reallocations from prime to government-only money funds to occur smoothly, there will have to be an elastic source of eligible instruments for government-only funds to use to be able to absorb new inflows. But with the SLR frustrating broker-dealers ability to be that elastic source, supply will have to come either from the U.S. Treasury or the Fed through the issuance of more Treasury bills or RRP, respectively (instruments that are practically the same and increased supplies of which have the same effect in terms of redrawing the financial system and creating winners and losers).

If anything, this discussion of policy options suggests that crafting policy solutions for the issues posed by shadow banking is not easy. We need to understand the totality of issues much better before we embark on drafting policy solutions. Solutions that involve crowding out the issuance of private money by the shadow banking system can solve cash pools' problem of a shortage of safe assets, but it can exacerbate real money investors' problem of inadequate yields relative to return targets. Dealer of Last Resort seems like a more even-handed solution, but one that should be accompanied not only by a re-regulation of G-SIBs at the core of the financial ecosystem, but also reforms to the ecosystem that G-SIBs inhabit and whose needs they intermediate. For example, through a reduction of imbalances in the distribution of present incomes (whether in the context of current account surplus *vs.* deficit countries, capital *vs.* labor or the 1% *vs.* the 99%) the size of wholesale funding markets could be reduced, and through an increase in retirement ages structural asset-liability mismatches may be reduced at pension funds – combined, such measures would mean less wholesale funding, less search for yield, and for a DoLR, fewer risks to backstop in aggregate.

Part VI – Conclusions

First, “there are no shadow banks, just a shadow banking system”:

The system described in this paper – a system of “money market funding of capital market lending” that is knit together by interactions between cash and bond portfolio managers intermediated through dealer balance sheets – is the shadow banking system. But it would be a mistake to label any part of this system as a shadow bank – each player already has a name and well-defined role to play:

broker-dealers are market makers; cash pools (essentially treasurers) manage short-term savings and seek safety; levered bond portfolios (hedge funds, mutual funds, and their blend, separate accounts) manage long-term savings and seek yield to beat their benchmarks; and real money accounts (pension funds, endowments, SWFs and households at large) allocate long-term savings to funds across the asset management complex that help them bridge their growing asset-liability mismatches.

The totality of their interaction gives rise to credit, maturity and liquidity transformation that is similar to the function played by traditional banks. But each of the above players are responsible for only a small piece of the action, and each piece is bound together by trades done in markets (intermediated through broker-dealer balance sheets), versus the balance sheet of one single bank.

In response to a question of where the ERM's anchor resided, Jean-Claude Trichet once quipped: "*L'ancre de système, c'est le système lui-même*" – the anchor of the system is the system itself. And just like that, a key message of this paper is... "there are no shadow banks, just a shadow banking system".

Second, on money and the matter of core vs. non-core liabilities vs. assets:

For institutional cash pools, money begins where M2 ends. What are typically referred to as financial intermediaries' core liabilities are noncore assets in institutional cash portfolios, and what are usually referred to as intermediaries noncore liabilities are core assets in institutional cash portfolios. The safest of safe assets in institutional cash portfolios are Treasury bills which do not count as money in benchmark measures of global liquidity, the mainstream economic literature and textbooks.

Third, on framing the rise of securities financing and the role of broker-dealers in an age of structural asset-liability mismatches and the increased use of leverage in asset management:

Repos in today's financial system are about the provision of working capital by broker-dealers to portfolio managers, much like real bills provided working capital for manufacturers and merchants in Bagehot's world of yore. Just as "working capital" traditionally refers to the short-term funding of real economy transactions with an aim to satisfy household and business consumers by producing and delivering real goods, repos effectively fund the working capital needs of levered bond portfolios in order to fund financial economy transactions in the form of levered bets on the direction of interest rates and credit spreads with an aim to satisfy retail and institutional investors' wealth aspirations by delivering financial goods in the form of excess returns over a benchmark.

One reason behind the shift in finance away from funding real economy transactions and toward funding financial economy transactions (the rise of securities financing – as evident from the increased provision of working capital to asset managers as opposed to traders and manufacturers) may be increased demand for the underwriting of equity-like returns with bond-like volatility for pension funds and other real money accounts amidst a proliferation of structural asset-liability mismatches. Asset managers use securities financing and derivatives as techniques to bridge the gap between rosy return expectations and the realities of a down-drift in yields on safe, long-term assets.

Far from its typical label of "casino banking," securities financing is an important form of finance, one that gained prominence with the proliferation of structural asset-liability mismatches at pension funds and other real money accounts, and one that is a natural extension of the demographic cycle of advanced economies where financing needs shift from funding the construction and purchase of

homes and consumption (cash flows from borrowing as a supplement to wages and salaries), to the funding of pension portfolios so that the cash flows they generate are in line with the cash flows promised to retirees (cash flows from investment portfolios as a substitute to wages and salaries). Broker-dealers, not banks are the central intermediaries in all this through their matched repo books.

Fourth, on improving the scope of the U.S. Financial Accounts (formerly the Flow of Funds):

The Flow of Funds accounts have been designed to show who borrows, who lends, and through what types of instruments. However, it offers no hints as to the asset–liability mismatches at pension funds and other real money accounts; it does not cover hedge funds and separate accounts, which make up an increasing share of real money portfolios; and it does not provide a breakdown of dealers’ matched repo books to gauge the volume of funding passed on to the buy-side, or the purpose of that funding – whether it was to fund a bond position, post cash collateral for securities borrowed, or raise liquidity for margin. Moreover, the Flow of Funds accounts end where derivatives begin – derivatives effectively separate the flow of risks (credit, duration, and foreign exchange risks) from the flow of funds – and hence looking at exposures to bonds without looking at accompanying derivatives makes the Flow of Funds accounts’ usefulness somewhat limited. And, without a sense for these measures, our ability to understand asset price dynamics is also limited.

To improve on this, the Flow of Funds should incorporate measures of structural asset–liability mismatches, and be augmented with a set of Flow of Collateral and Flow of Risk satellite accounts to tabulate the types of collateral that back the flow of funds and risks across the ecosystem.

Improvements to financial accounting would help us see beyond Bernanke’s savings glut hypothesis and Shin’s banking glut hypothesis as the only possible reasons behind the pre-crisis compression of the Treasury term premium and mortgage spreads, respectively, and see these developments also as a result of the massive run-up in the volume of levered bids for these securities coming from asset managers, financed through broker-dealers’ matched repo books – “the leveraged bids glut”.

Fifth, and finally, on crafting policy solutions that deal with the issues posed by shadow banking:

Economists and policymakers need to understand the totality of issues much better before they embark on drafting policy solutions for shadow banking. Solutions that involve crowding out the issuance of private money by the shadow banking system can solve cash pools problem of a shortage of safe assets, but it can exacerbate real money investors’ problem of inadequate yields relative to return targets. Dealer of Last Resort seems like a more even-handed solution, but one that should be accompanied not only by a re-regulation of G-SIBs at the core of the financial ecosystem, but also reforms to the ecosystem that G-SIBs “merely” inhabit and whose needs they intermediate. Through a reduction of imbalances in the distribution of present incomes (whether in the context of current account surplus *vs.* deficit countries, capital *vs.* labor or the 1% *vs.* the 99%) the size of wholesale funding markets could be reduced, and through an increase in retirement ages asset–liability mismatches may be reduced at pension funds. Combined, such measures would mean less wholesale funding, less search for yield, and for a DoLR, fewer risks to backstop in the aggregate.

Figure 1: The Money Matrix

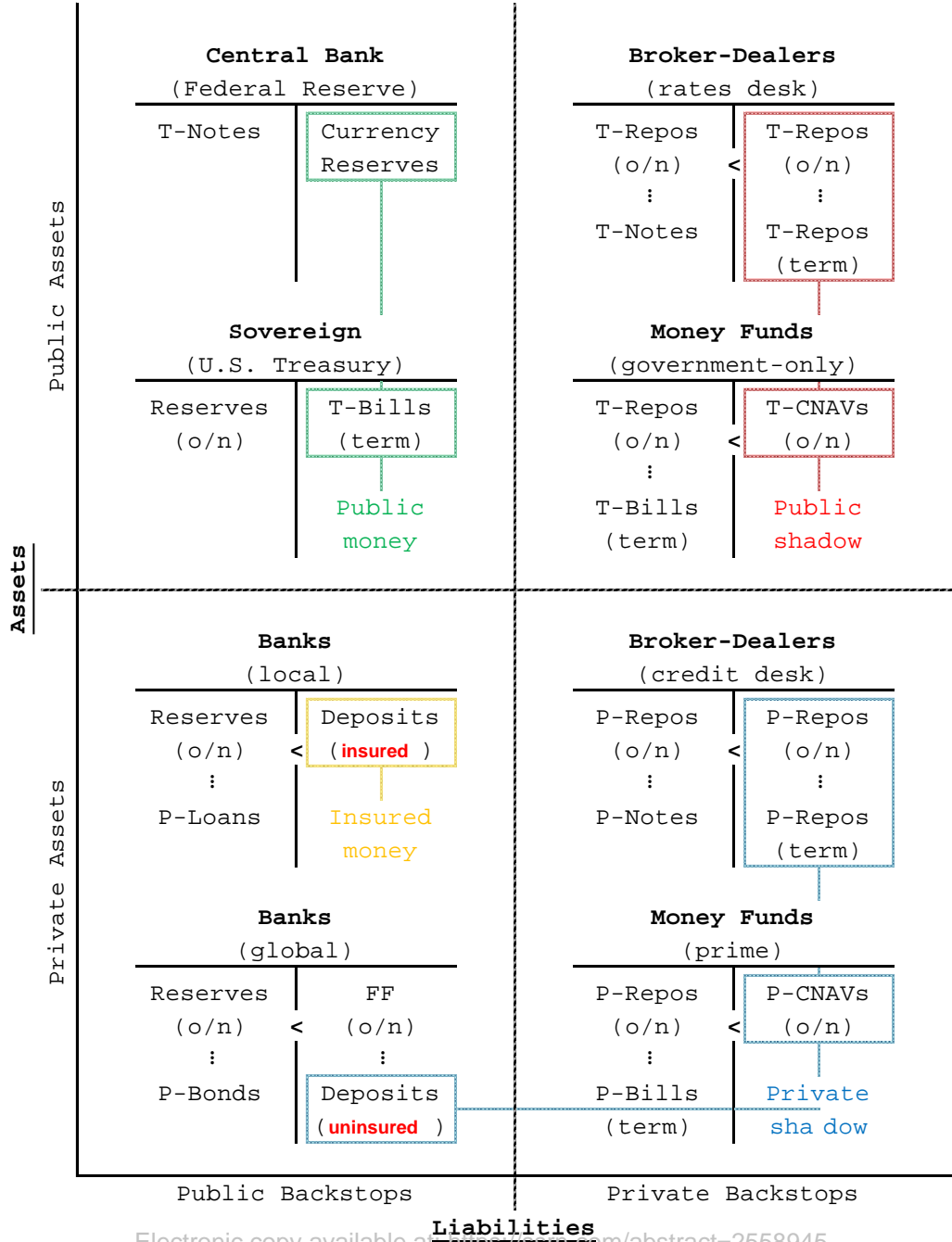

T-Bills = Treasury bills
T-Notes = Treasury notes
T-Repos = Treasury repos
T-CNAVs = Treasury CNAVs

P-Bills = Private bills (CDs, commercial paper)
P-Notes = Private bonds (corporate bonds, RMBS)
P-Repos = Private repos
P-CNAVs = Private CNAVs

FF = fed funds borrowed

Source: Pozsar (2014)

Figure 2: The Core Entities of the Shadow Banking System

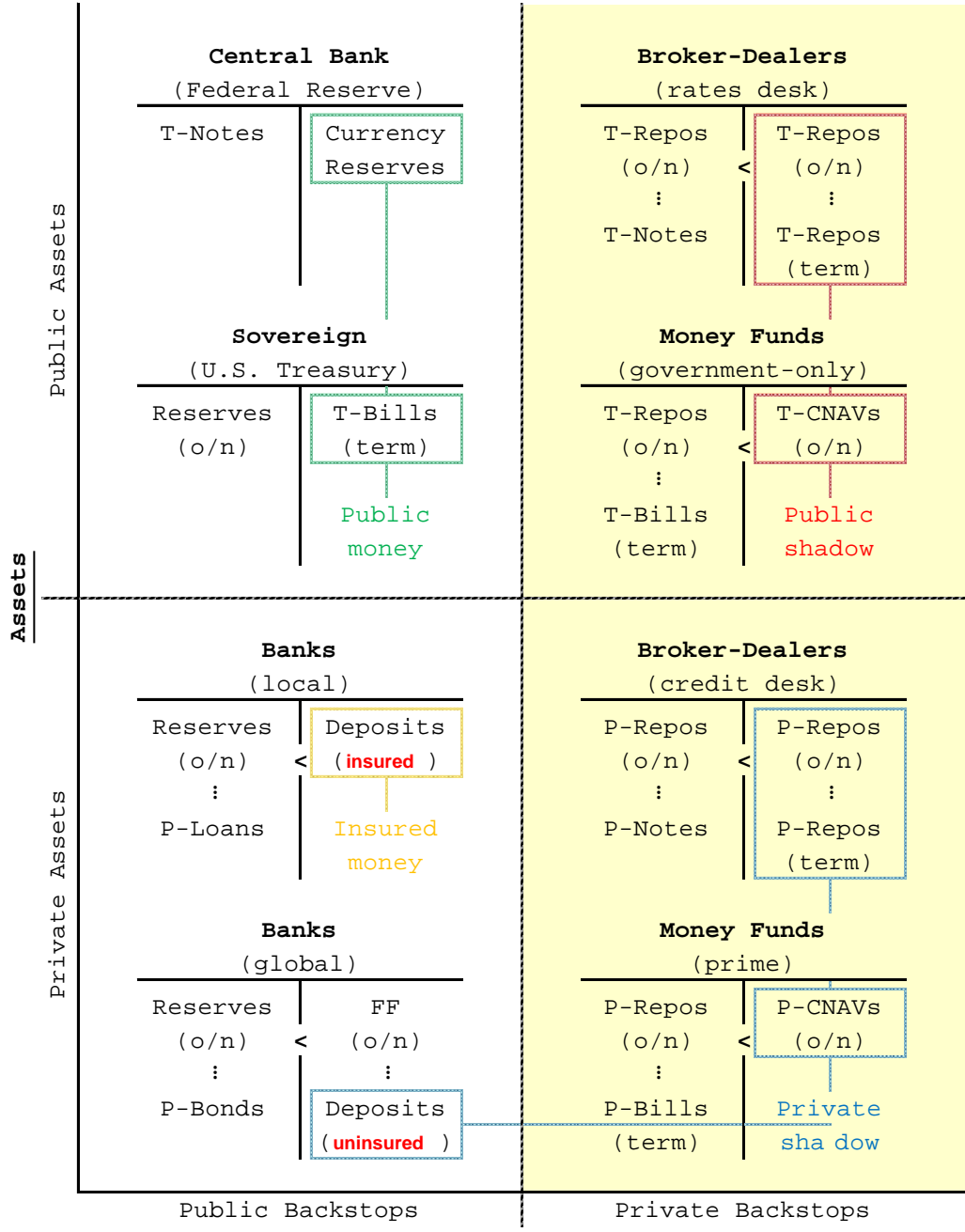

Source: Pozsar (2014)

Figure 3: The Shadow Banking System and G-SIBs

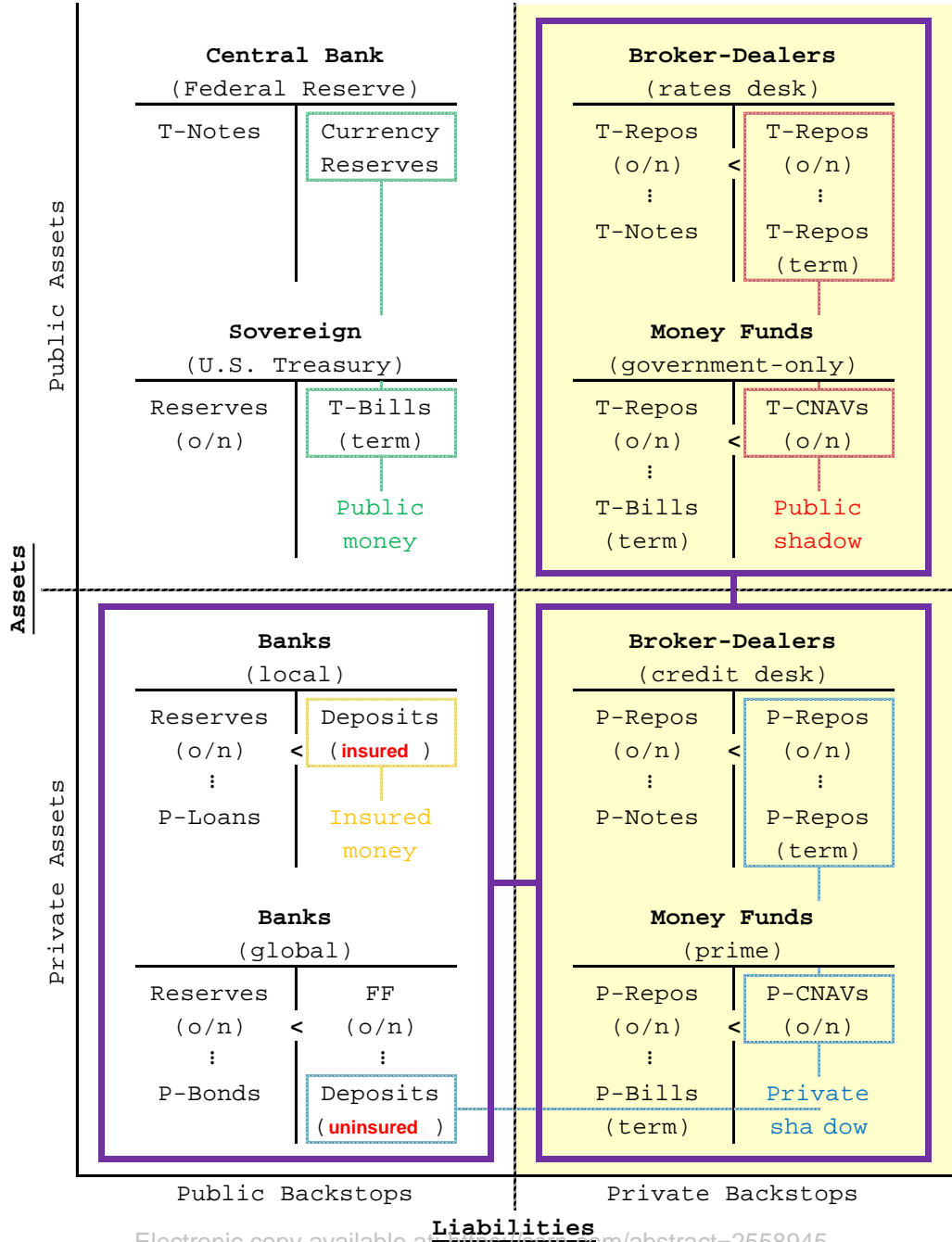

Source: Pozsar (2014)

Figure 4: Institutional Cash Pools

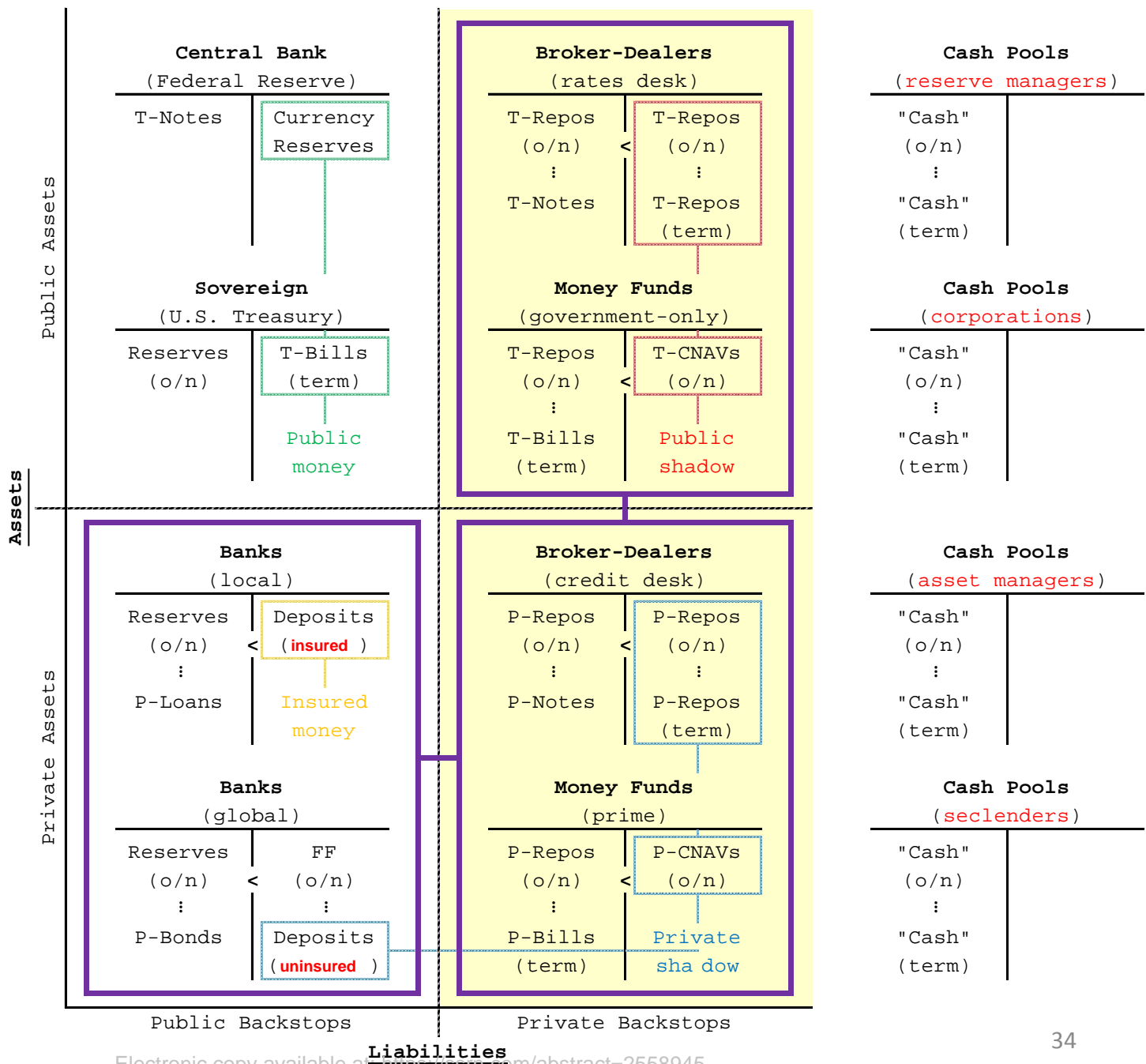

Source: Pozsar (2014)

Figure 5: Institutional Cash Pools by Type and Size, \$ billion

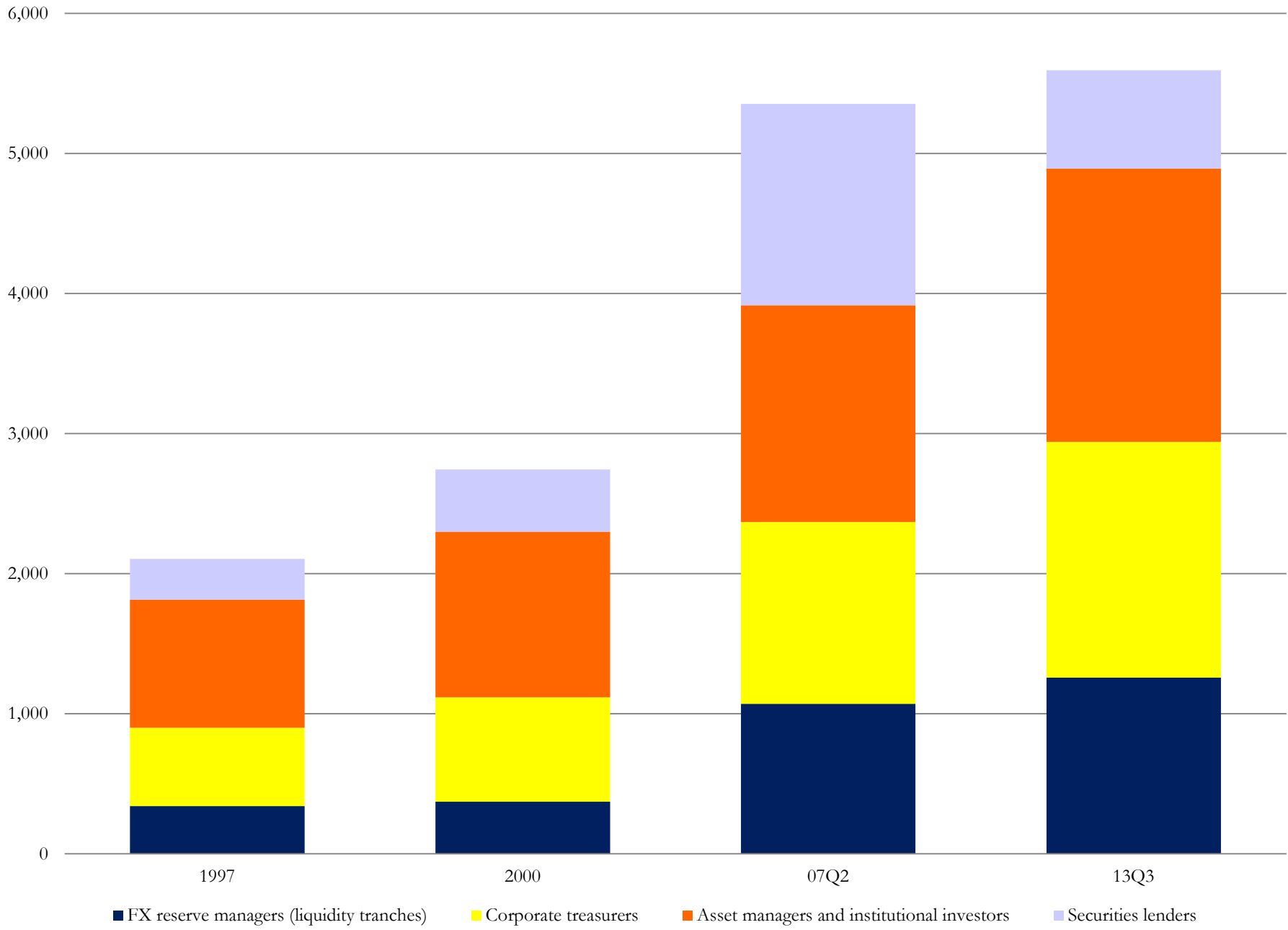

Source: Pozsar (2014)

Electronic copy available at: <https://ssrn.com/abstract=2558945>

Figure 6: The Liquidity (or Monetary) Premium of U.S. Treasury Bills

Panel A: One-Month Interest Rates

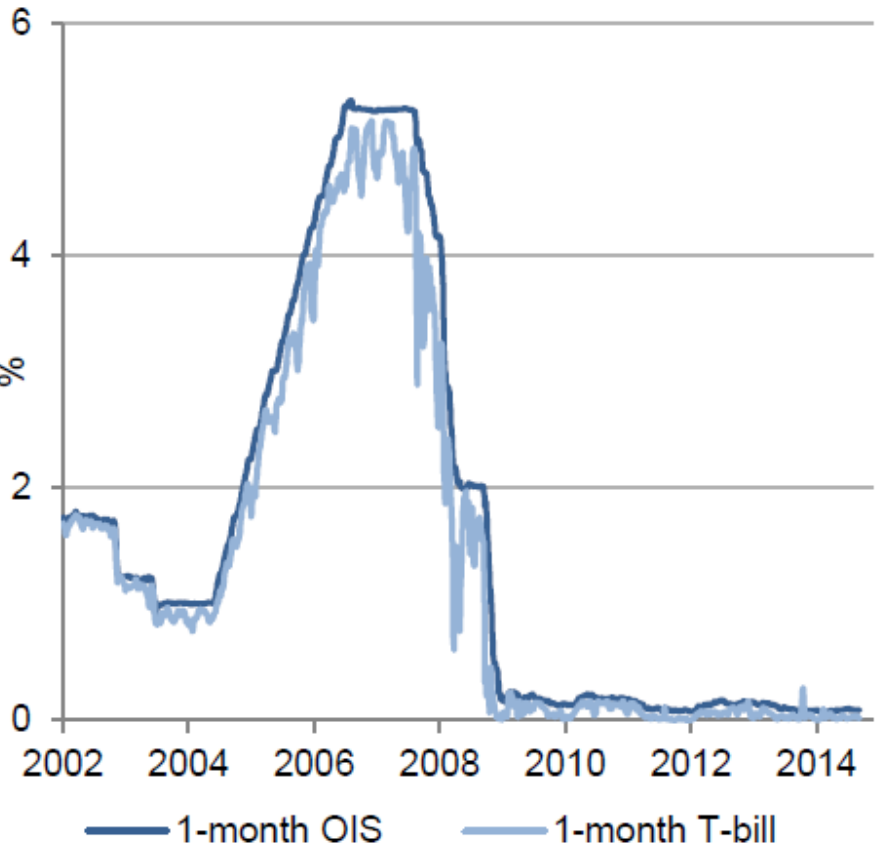

Panel B: Liquidity Premium on Short-Term T-Bills

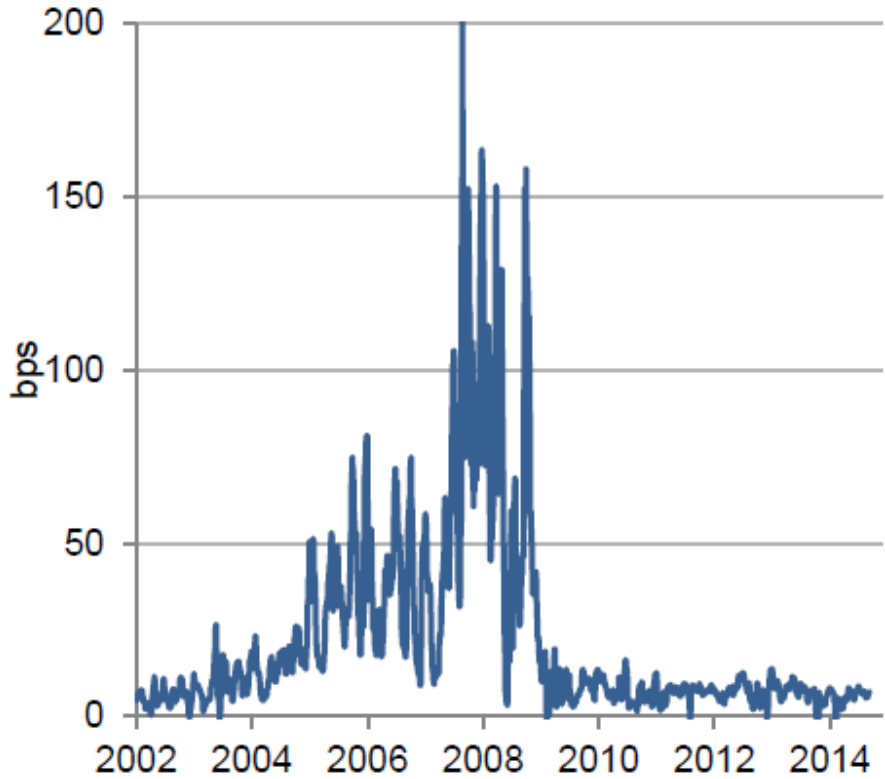

Source: Greenwood, Hanson, Rudolph and Summers (2014) <http://www.gsm.com/abstract=2558945>

Figure 7: Size Matters

[1] Cash pools do not have access to M0, M1 or M2...

=> ...for cash pools, money begins where M2 ends.

[2] Cash pools cannot get enough Treasury bills...

=> ...inelastic supply of safe, short-term assets.

[3] Cash pools have limits on un-secured credit risk...

=> ...inelastic demand for un-insured bank deposits

[4] Cash pools opt for second best alternatives...

=> ...the elastic middle of shadow money claims.

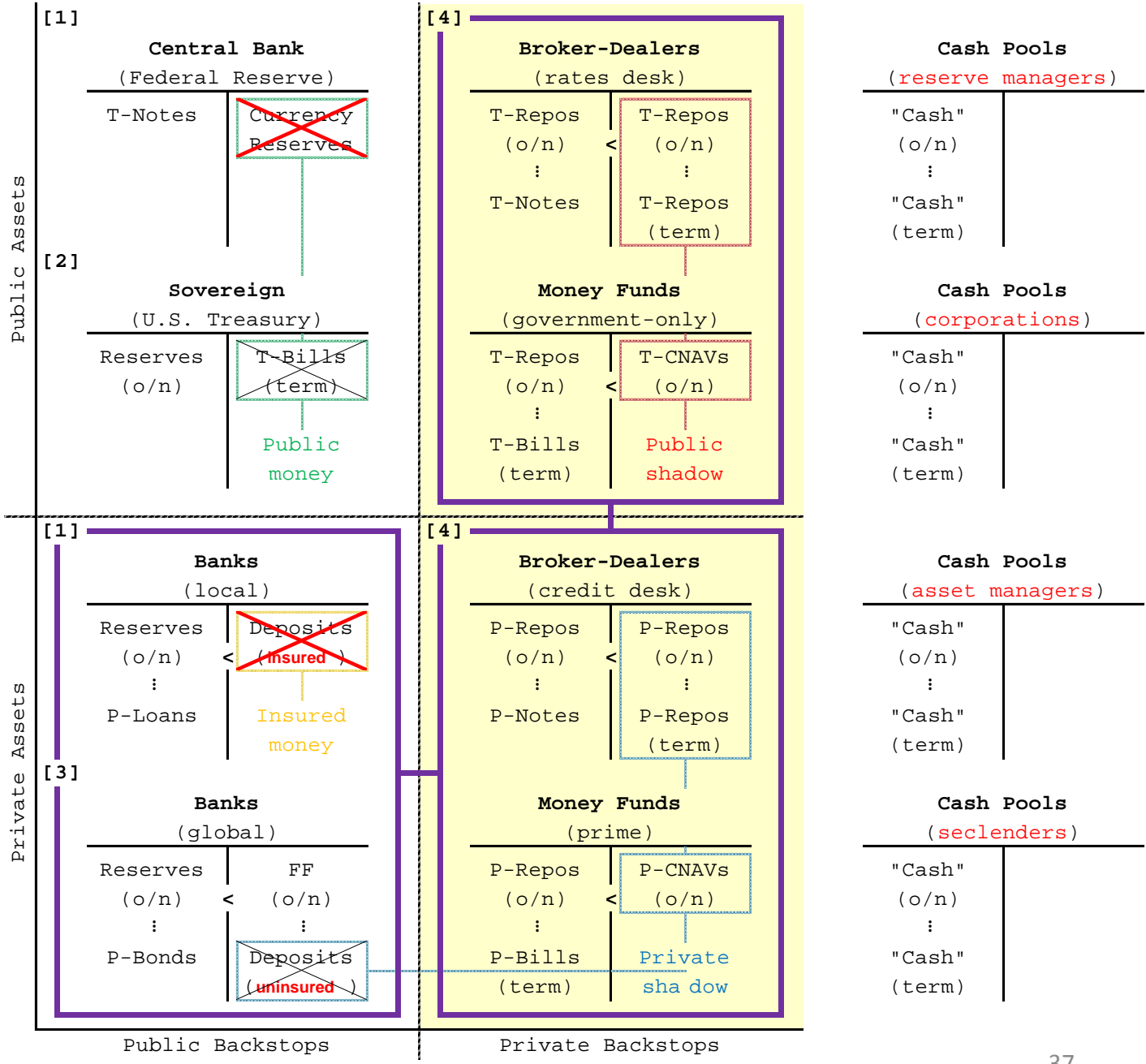

Figure 8: Between a Rock and a Hard Place

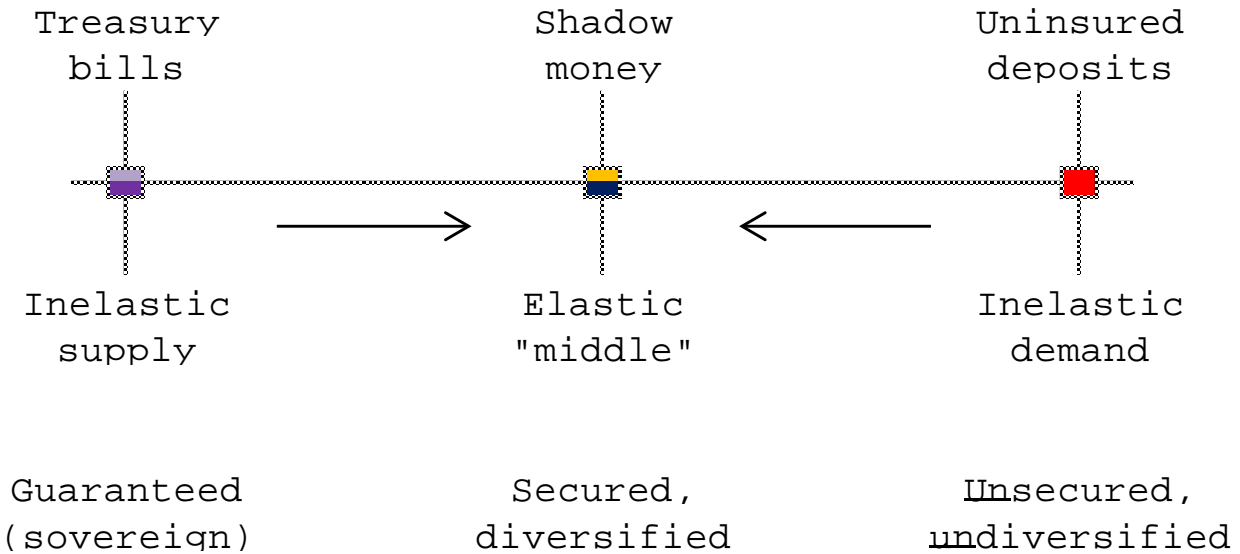
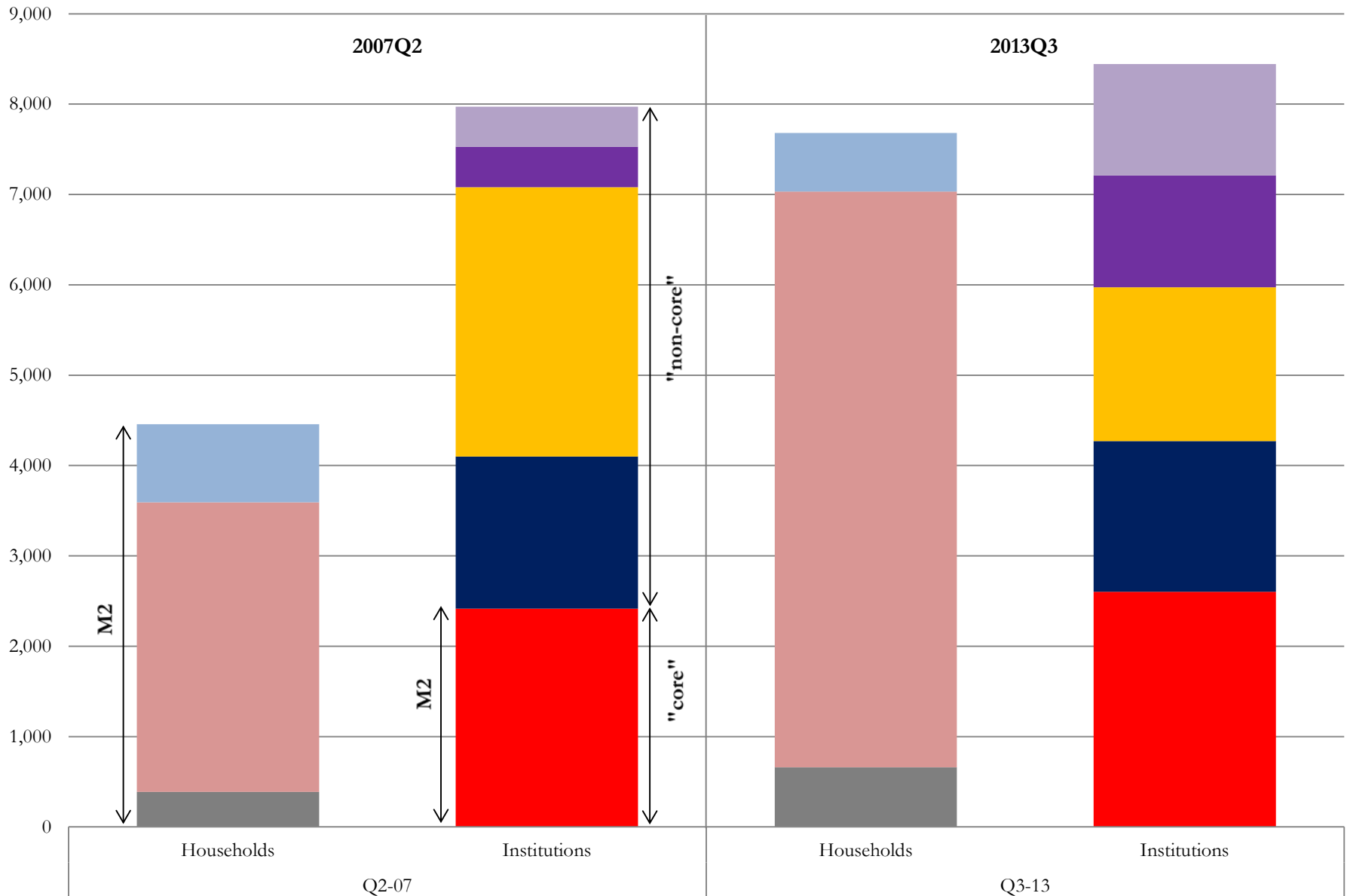

Figure 9: "Core" vs. "Non-Core" - Vantage Points Matter, \$ billion



- Bank Deposits [uninsured]
- Money funds [institutional-class]
- Dealer Repos
- Currency [held onshore]
- Bank Deposits [insured]
- Money funds [retail-class]
- U.S. Treasury bills
- U.S. Treasury notes

Source: Pozsar (2014, forthcoming)

Figure 10: Re-Imagining Broker-Dealers as Mehrling's Money Dealers, \$ billion

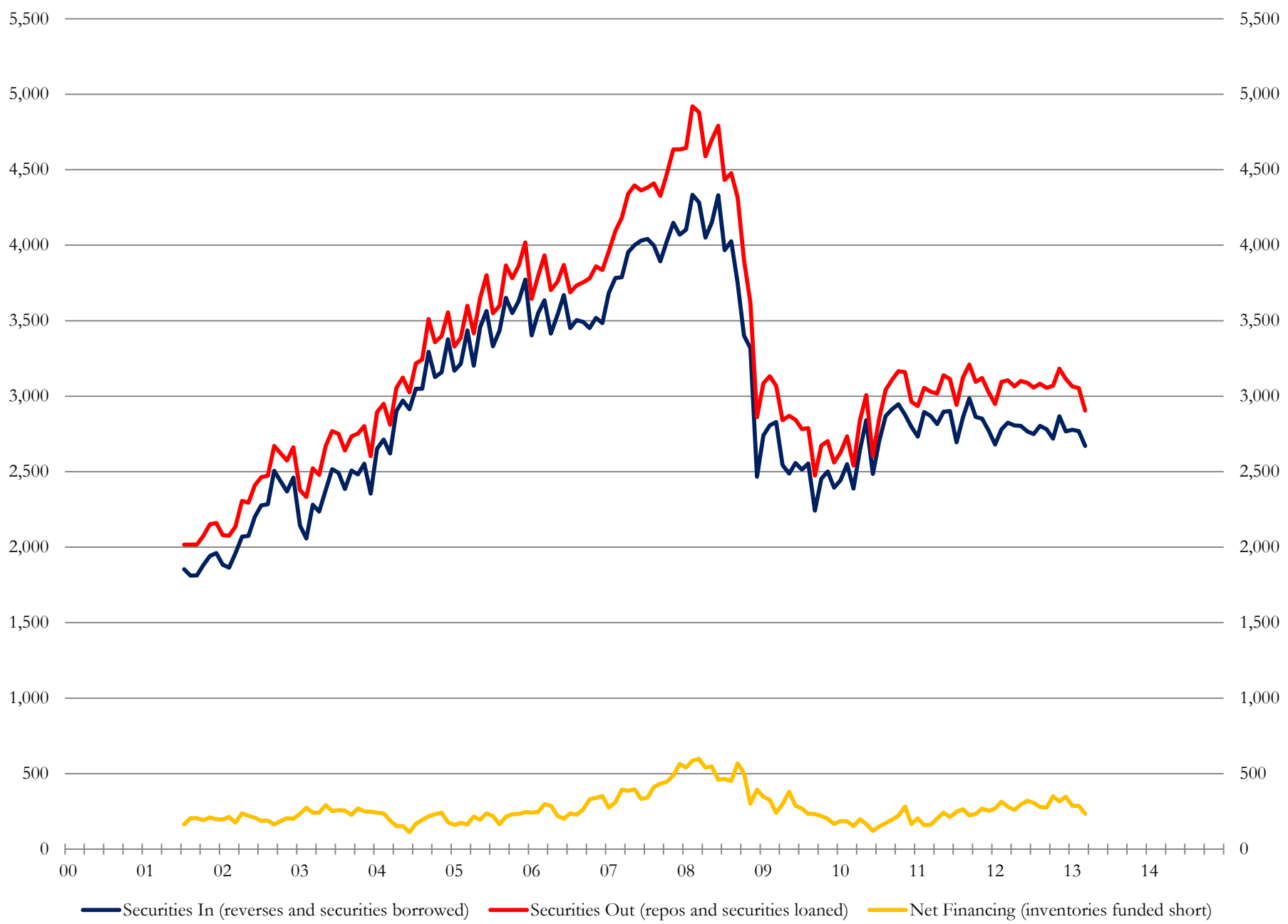

Source: Federal Reserve Bank of New York (<https://ssrn.com/abstract=2558945>)

Figure 11: Re-Imagining Broker-Dealers as Mehrling's Money Dealers, \$ billion

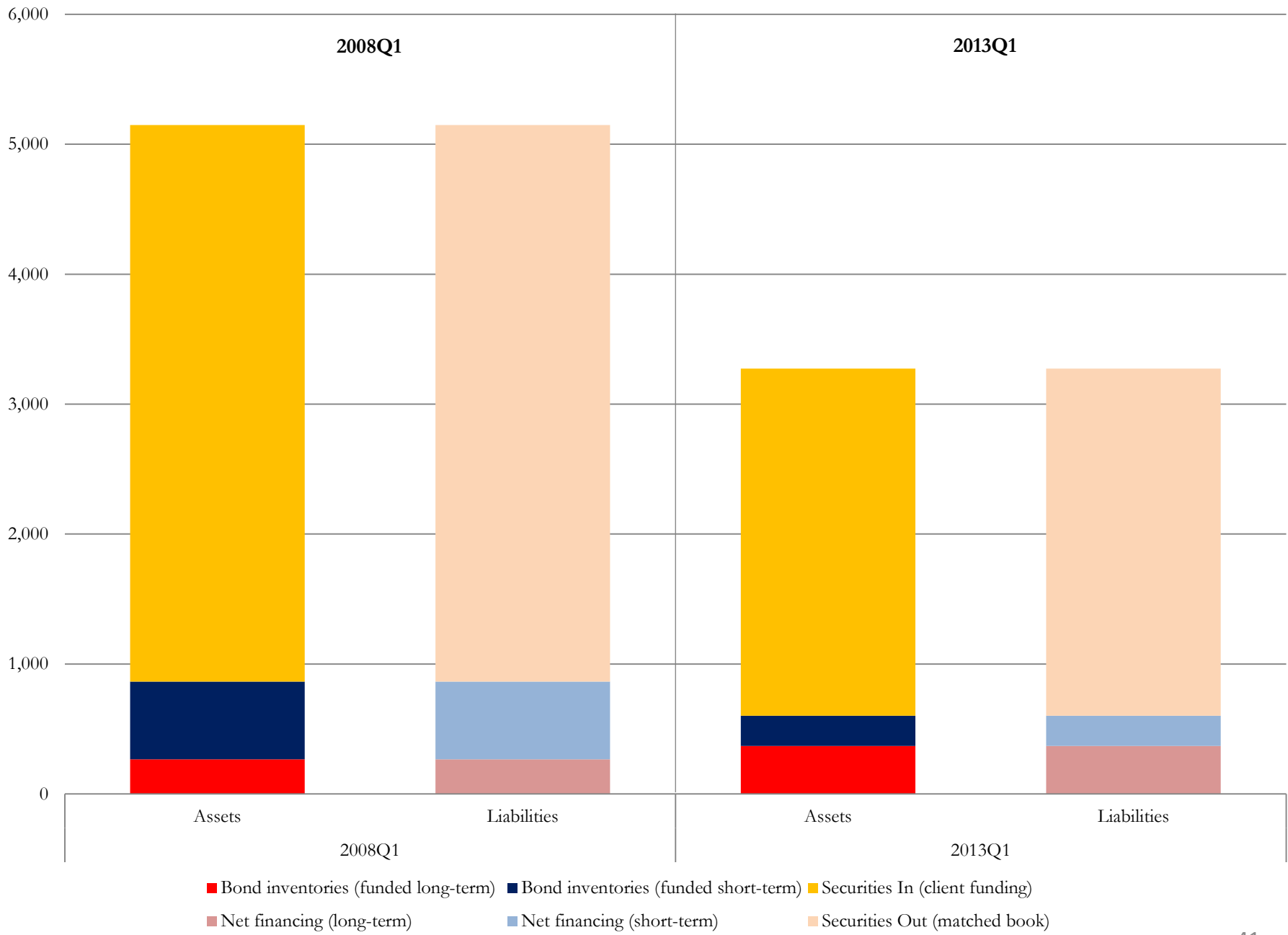

Source: Federal Reserve Board (Flow of Funds) and Federal Reserve Bank of New York (FR2004)

Figure 12: Re-Imagining Broker-Dealers as Mehrling's Money Dealers, \$ billion

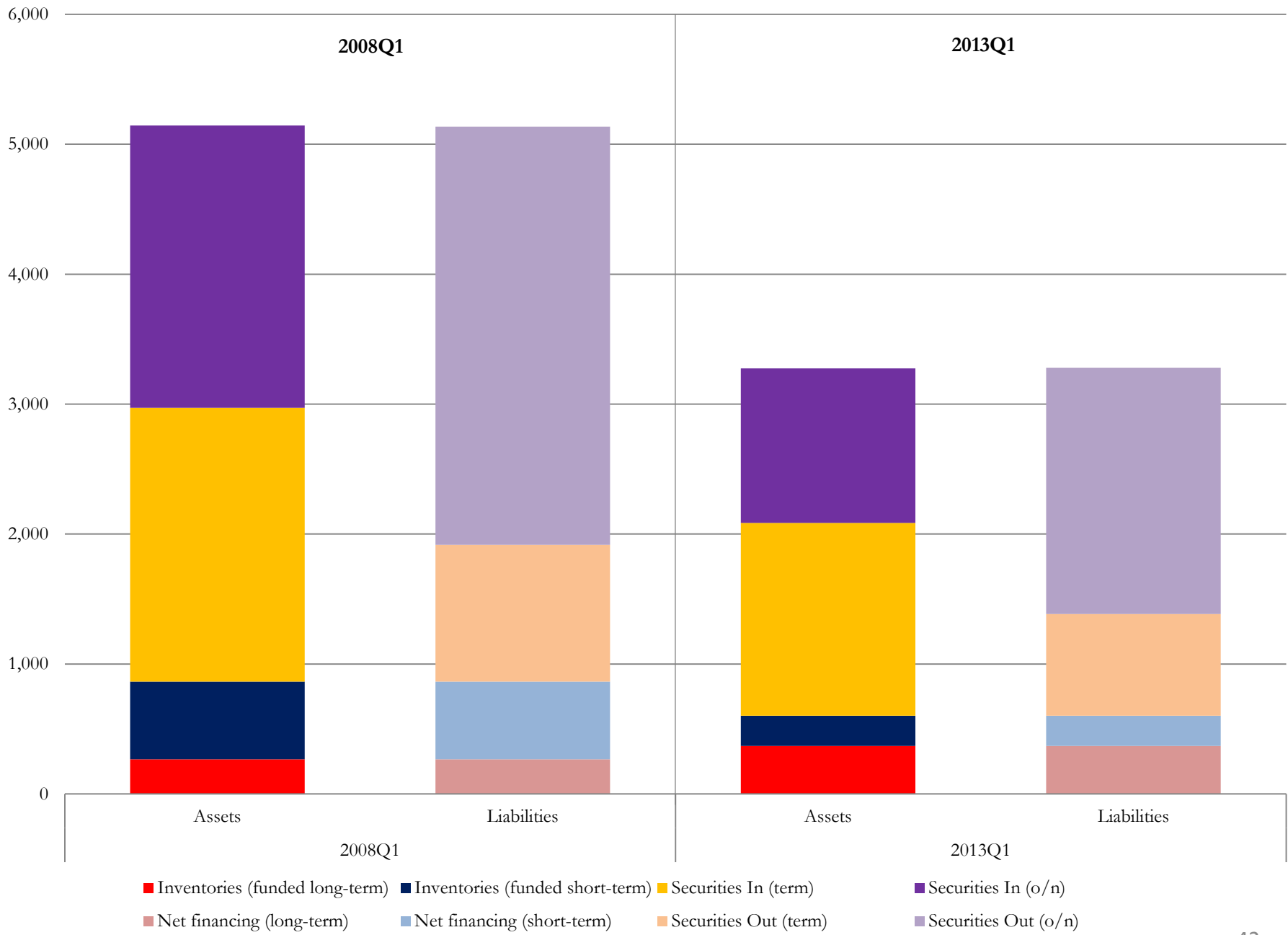

Source: Federal Reserve Board (Flow of Funds) and Federal Reserve Bank of New York (FR2004)

Figure 13: Re-Imagining Broker-Dealers as Mehrling's Money Dealers, \$ billion

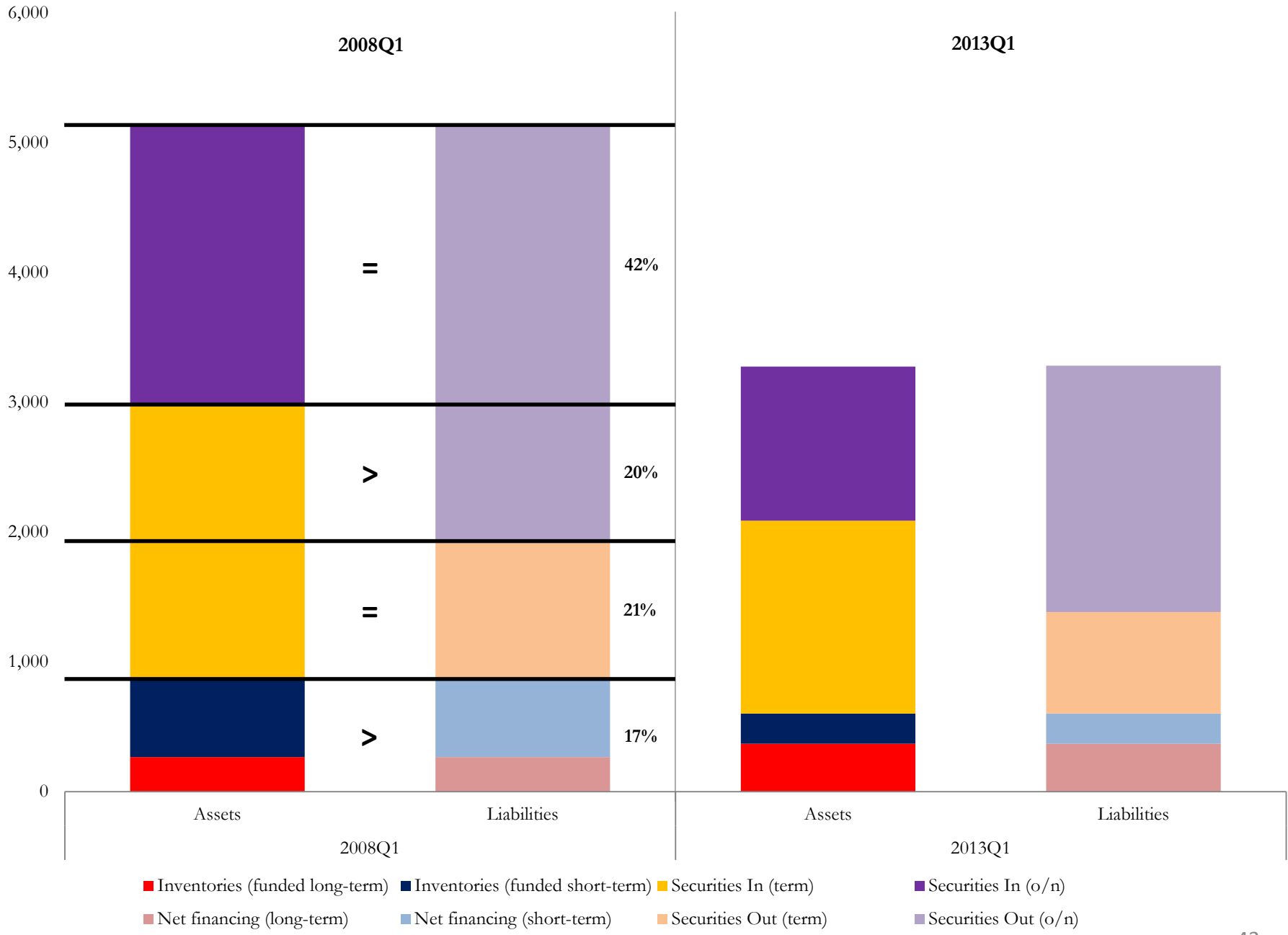

Source: Federal Reserve Board (Flow of Funds) and Federal Reserve Bank of New York (FR2004)

Figure 14: Re-Imagining Broker-Dealers as Mehrling's Money Dealers, \$ billion

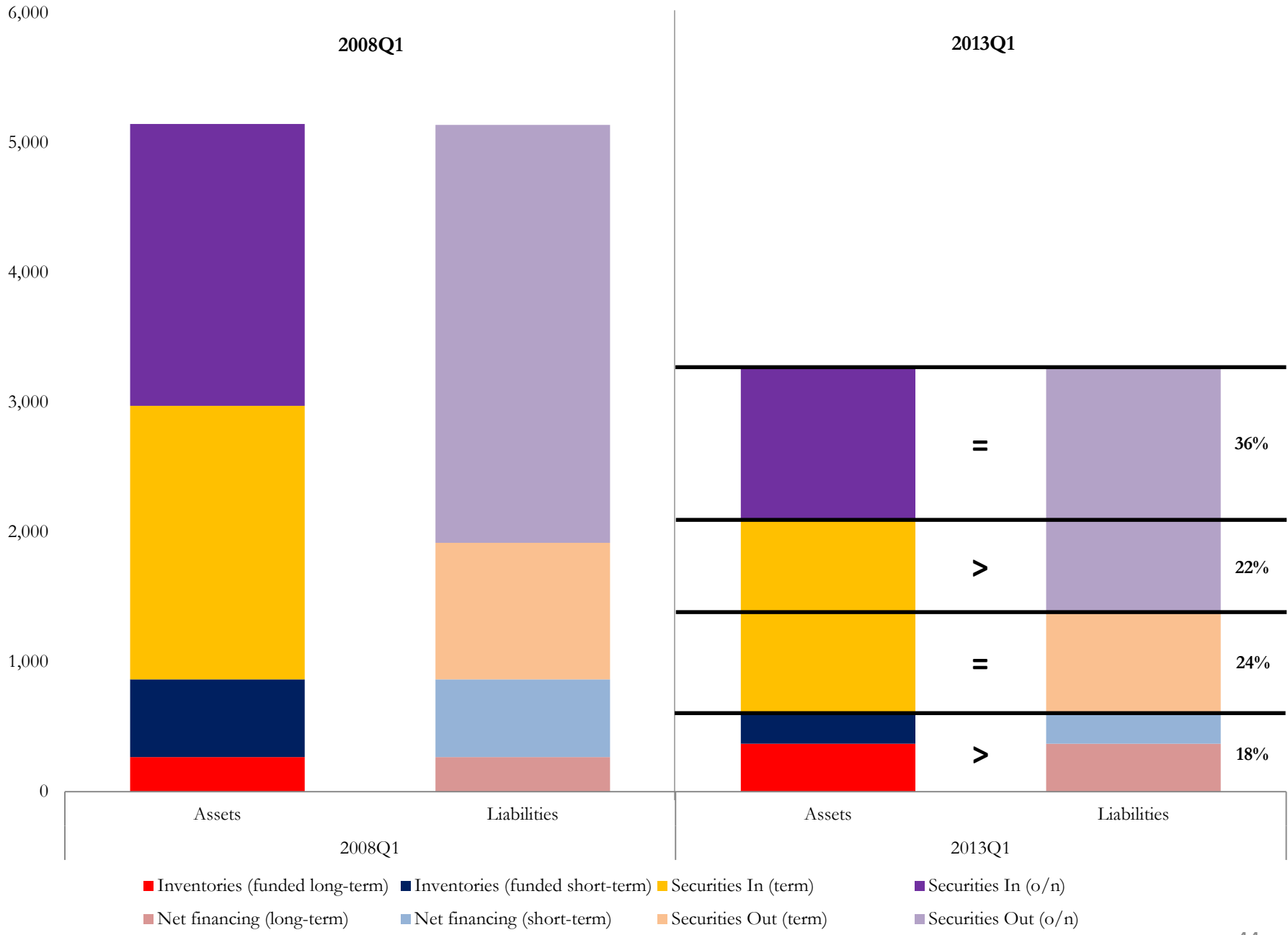

Source: Federal Reserve Board (Flow of Funds) and Federal Reserve Bank of New York (FR2004)

Figure 15: Prime Brokerage vs. Fixed Income Securities Financing, \$ billion

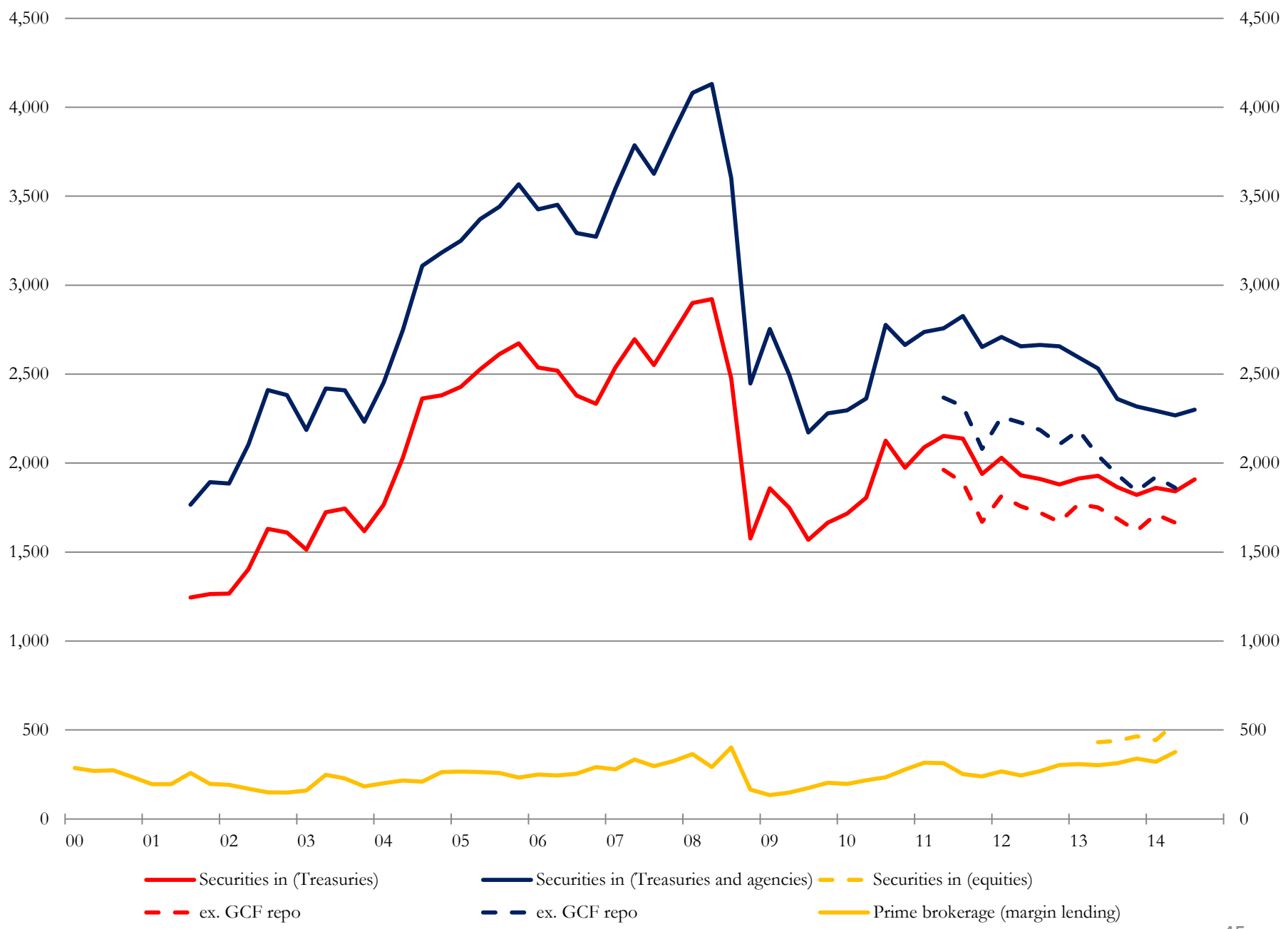

Source: Federal Reserve Bank of New York (FR2004) and Federal Reserve Board (Flow of Funds)

Figure 16: The Sources of Hedge Fund Leverage, *percent*

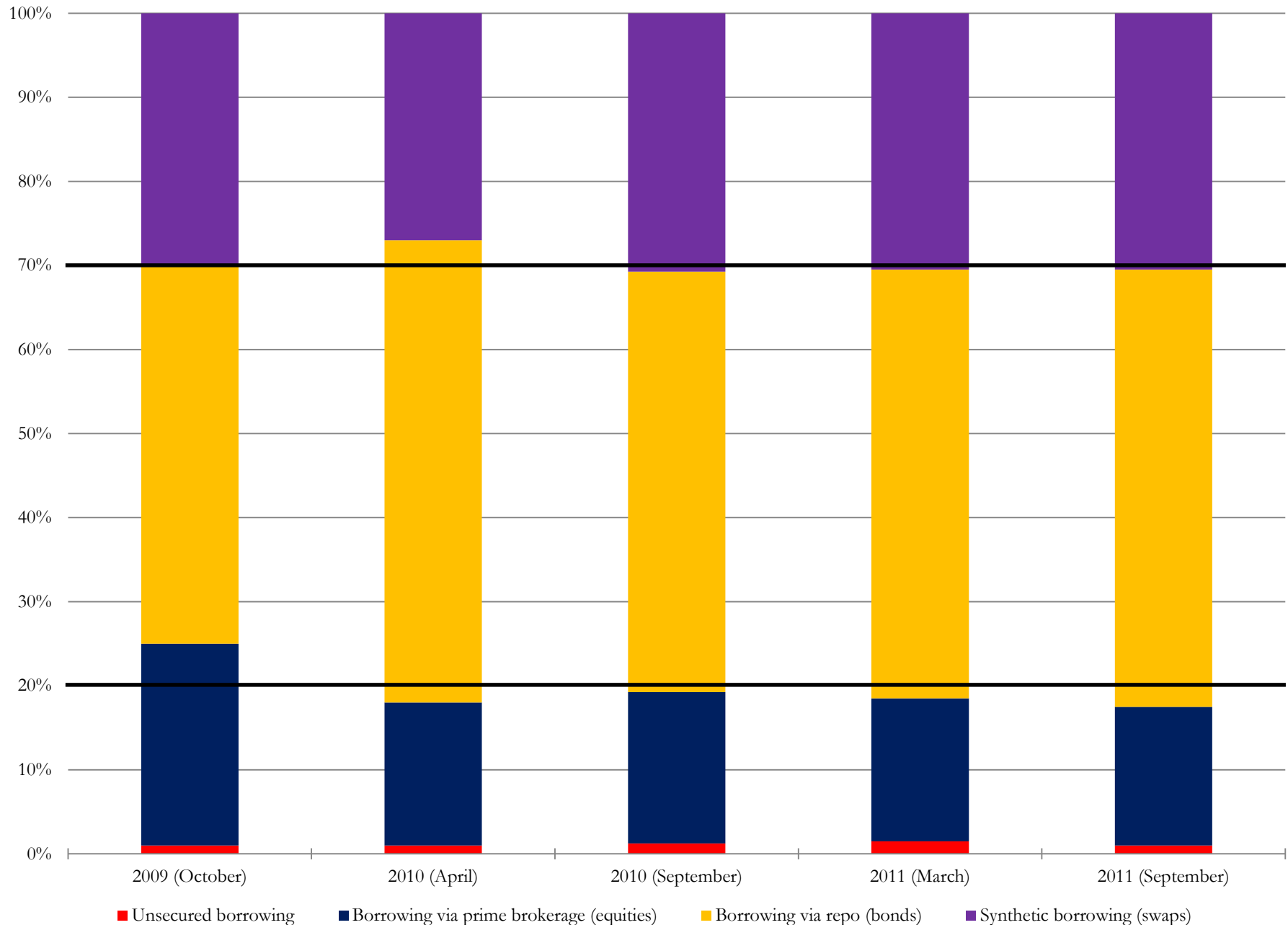

Source: Financial Services Authority (February, 2012) <http://fsa.gov.uk/abstract=2558945>

Figure 17: It's Not Only Hedge Funds - Three Distinct Types of Levered Bond Portfolios

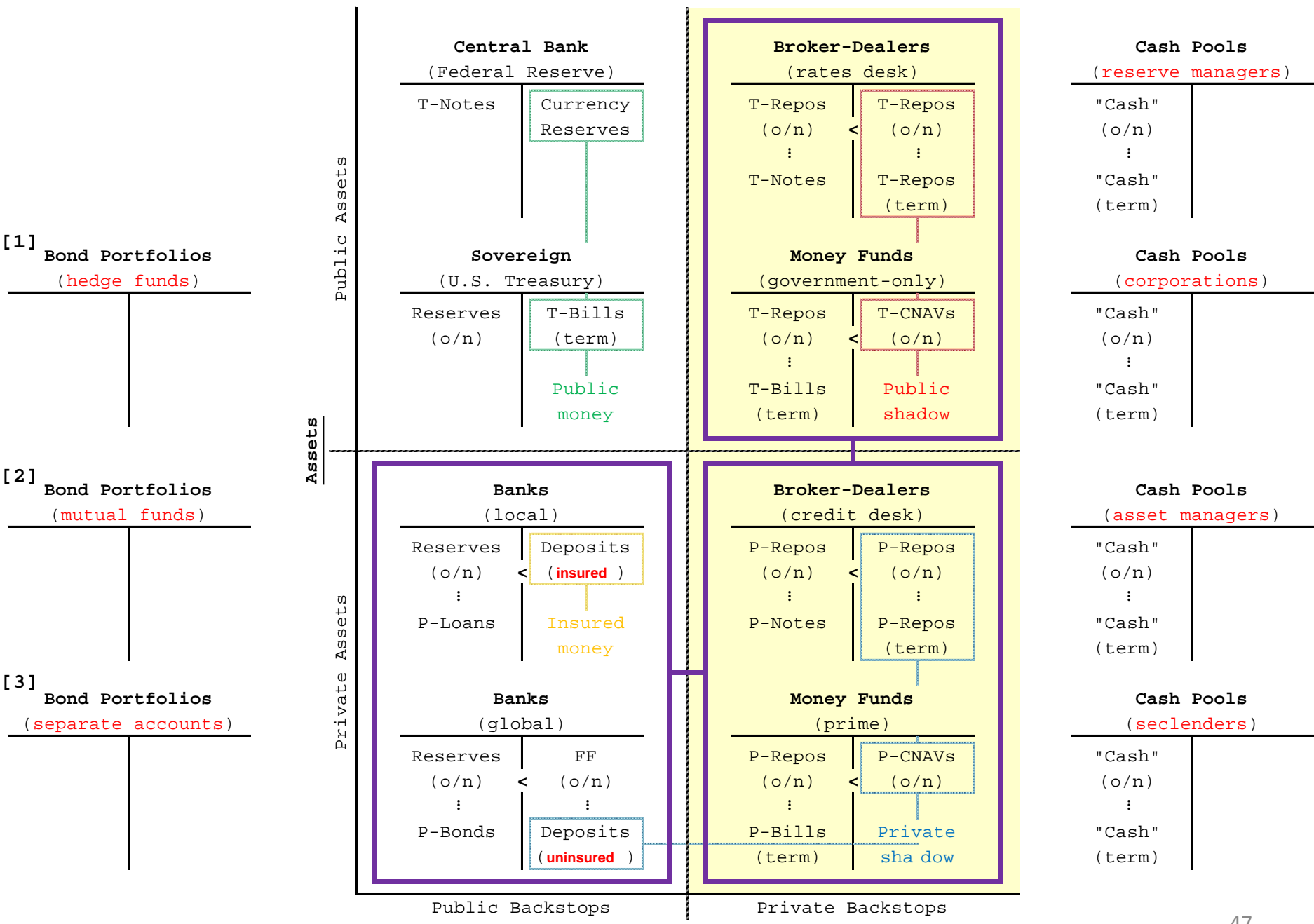

Source: Pozsar (2014)

Figure 18: The Secular Rise of Structural Asset-Liability Mismatches, *percent*

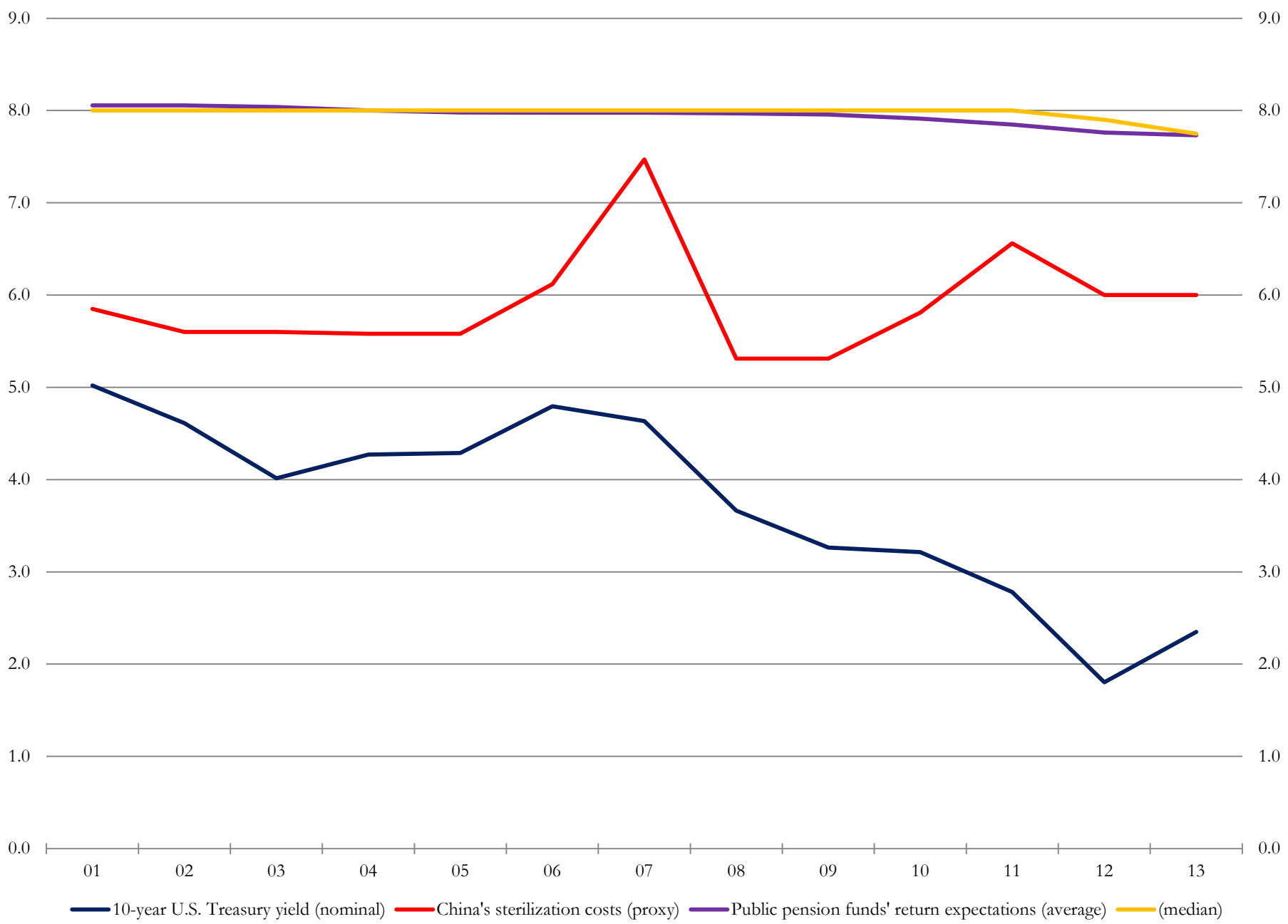

Source: Federal Reserve Board, PBOC, Public Fund Survey

Figure 19: Levered Bond Portfolios and Three Distinct Types of Leverage

Source: Pozsar (2014)

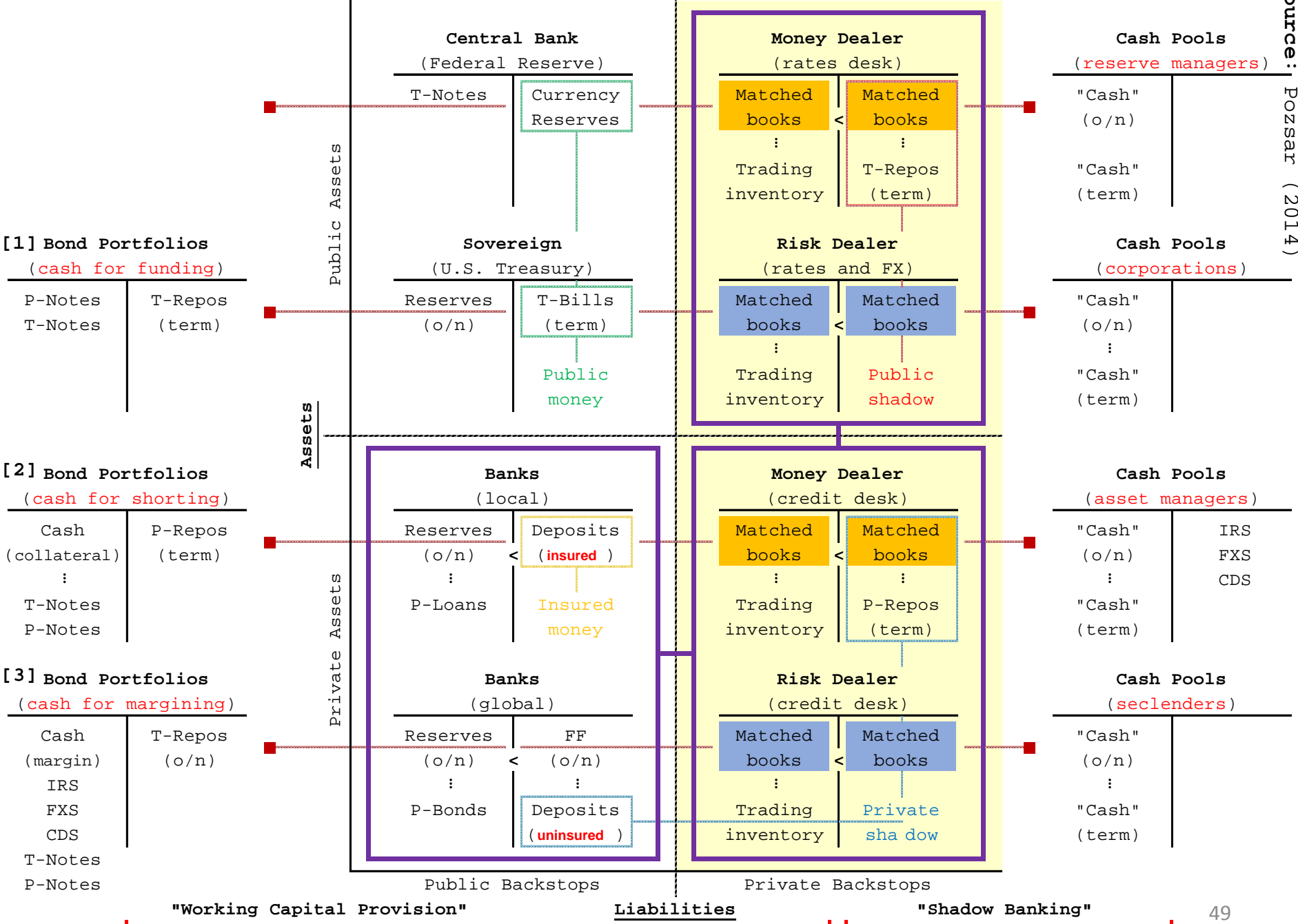
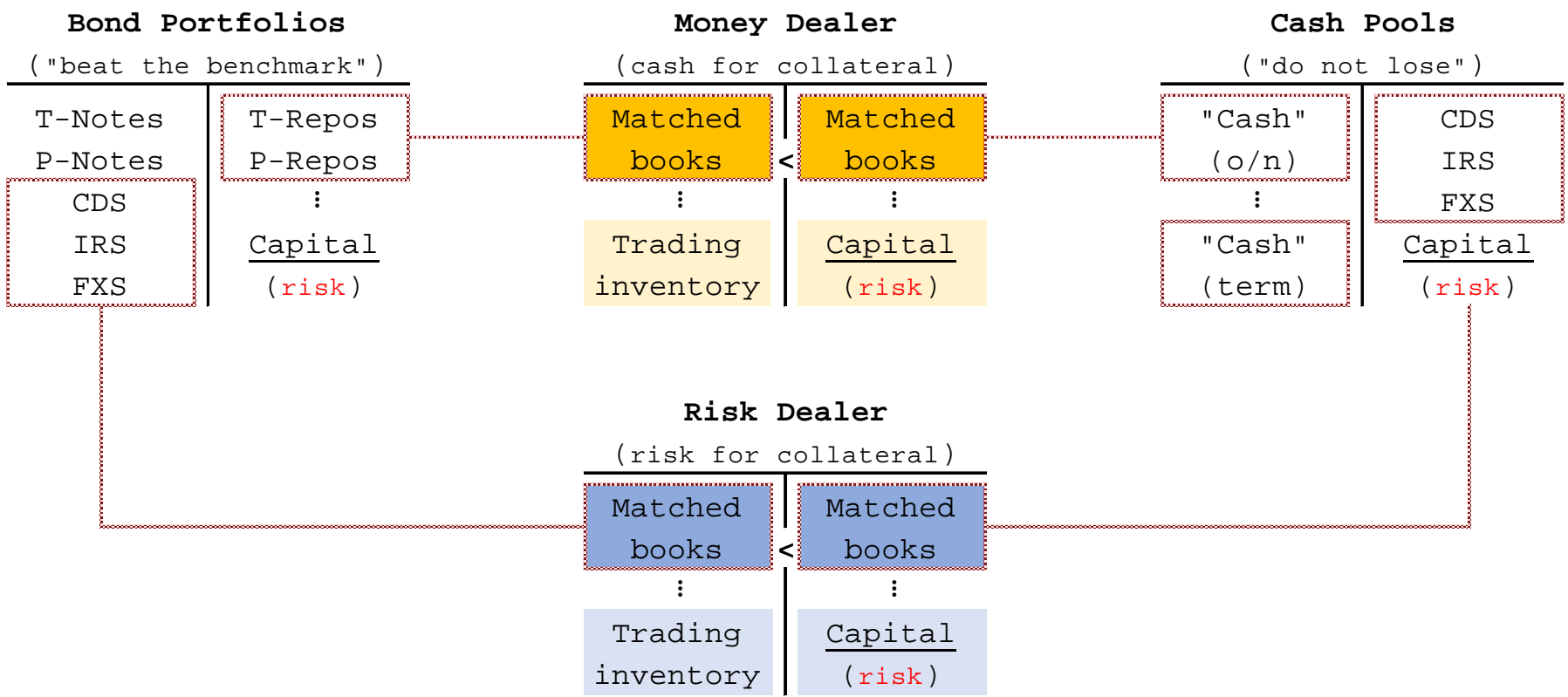
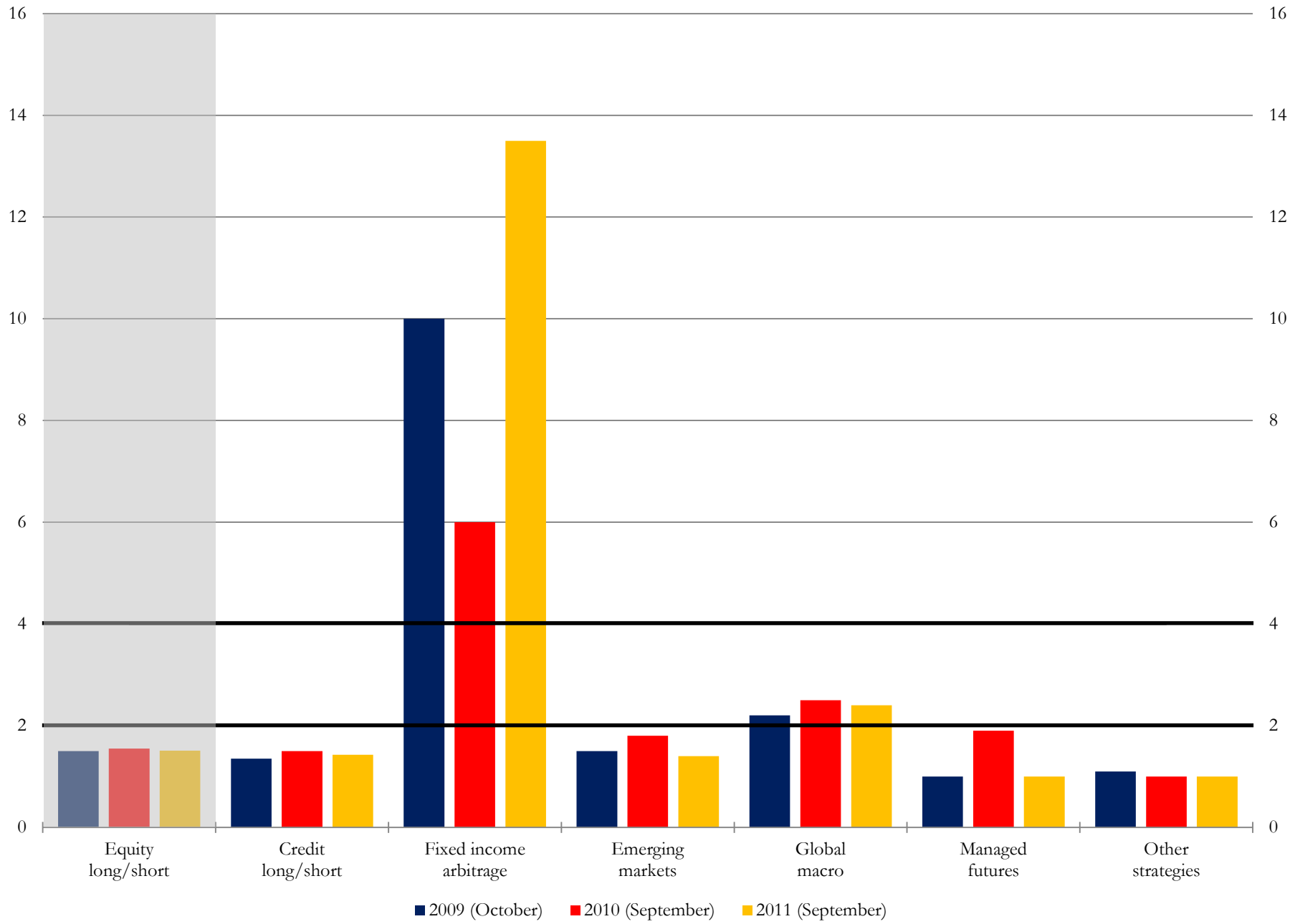

Figure 20: The Dealer Ecosystem



Source: Mehrling, Pozsar, Sweeney and Neilson, Bagehot Was a Shadow Banker (2013)

Figure 21: Degrees of Hedge Fund Leverage, borrowing plus NAV as a multiple of NAV



Source: Financial Services Authority (February, 2012) <http://www.fsa.gov/abstract=2558945>

Figure 22: Degrees of Mutual Fund Leverage - PIMCO Total Return Fund, \$ thousand, as of 3/31/2014

	<u>Assets</u>	<u>Liabilities</u>	<u>%/NAV</u>
[1] Cash Pool (public and shadow money daims):			
Cash	34,219		0.0%
U.S. Treasury bills (sovereign)	71,039		0.0%
U.S. Treasury repos (broker-dealers)	2,035,700		0.9%
Certificates of deposit (global banks)	1,896,593		0.8%
PIMCO Central Liquidity Fund (FNAV)	18,312,080		7.9%
"Off-matrix" miscellaneous daims (credit)	1,286,223		0.6%
<i>Subtotal</i>	<i>23,635,854</i>	-	<i>10.2%</i>
[2] Derivatives (rates, FX, credit and vol overlays and hedges):			
Futures	102,668	4,292	
Forwards	148,100	365,553	
Options	-	636,968	
Swaps	437,661	94,647	
<i>Subtotal</i>	<i>688,429</i>	<i>1,101,460</i>	<i>-0.2%</i>
[3] Bonds (funded, loaned and short positions):			
Payable for repo borrowings		1,124,969	-0.5%
! (average repo during the period ended 3/31/14)		5,726,277	-2.5%
Payable for sale-buyback transactions		774,933	-0.3%
Payable for short sales		1,541,302	-0.7%
<i>Subtotal</i>	<i>-</i>	<i>3,441,204</i>	<i>-1.5%</i>
[4] Bonds (long positions):			
U.S. Treasury notes	78,021,479		33.6%
U.S. agency RMBS	47,569,505		20.5%
Corporate bonds	31,300,450		13.5%
Sovereign bonds	24,055,128		10.4%
Residential MBS	14,855,692		6.4%
Municipal bonds	9,096,212		3.9%
ABS	6,552,258		2.8%
Loans	929,231		0.4%
Convertibles	209,154		0.1%
<i>Subtotal</i>	<i>212,589,109</i>	<i>-</i>	<i>91.7%</i>
Miscellaneous:	22,754,146	23,211,246	-0.2%
	259,667,538	27,753,910	231,913,628

Check (%):

100.0%

Figure 23: The Flow of Funds Accounts vs. Reality, percent, as of 3/31/14

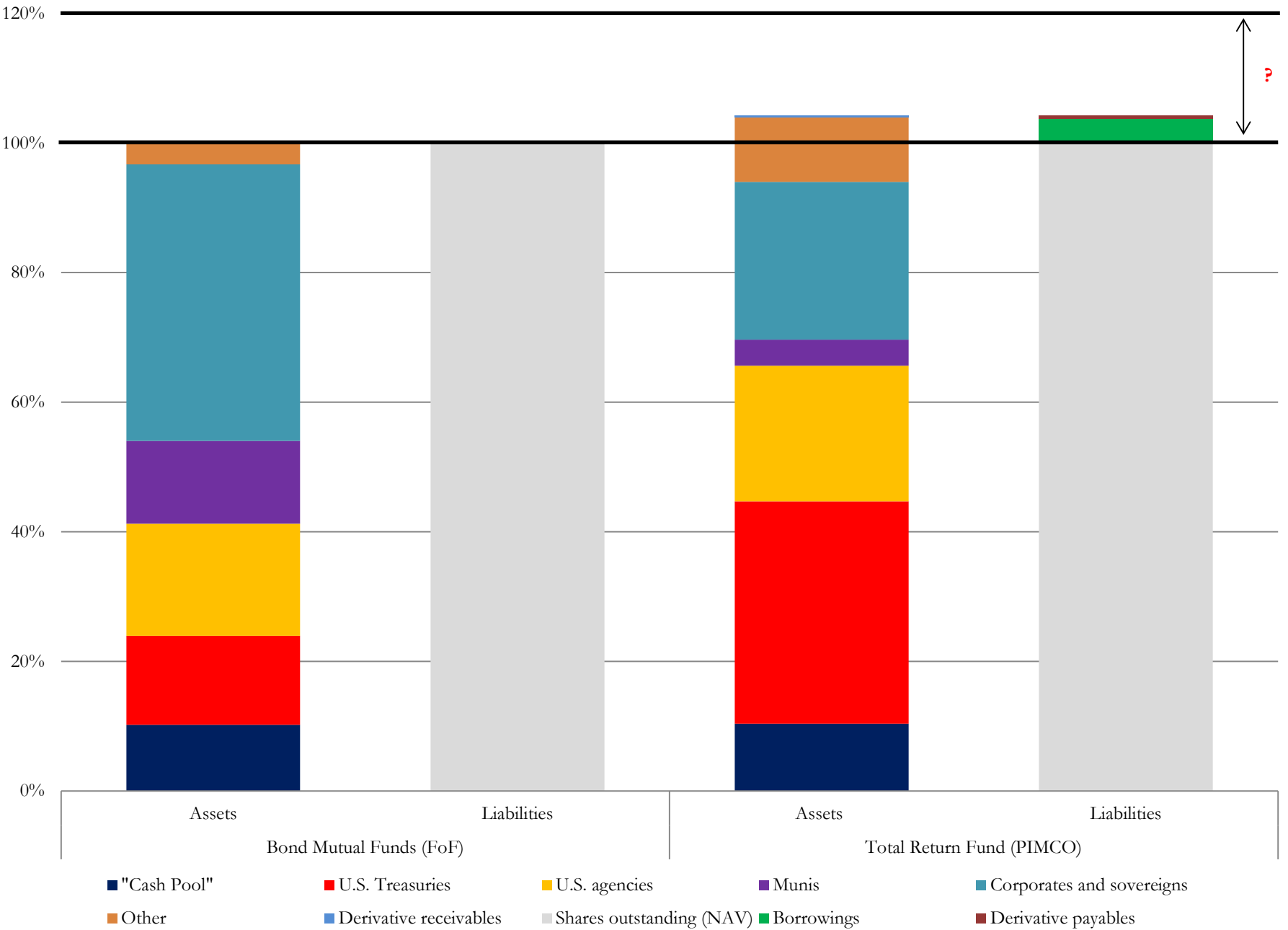

Source: Federal Reserve Board (Flow of Funds) and PIMCO (Total Return Fund annual report)

Figure 24: The Blurring Line Between Pure Alphas and Pure Betas - The Rise of Levered Betas

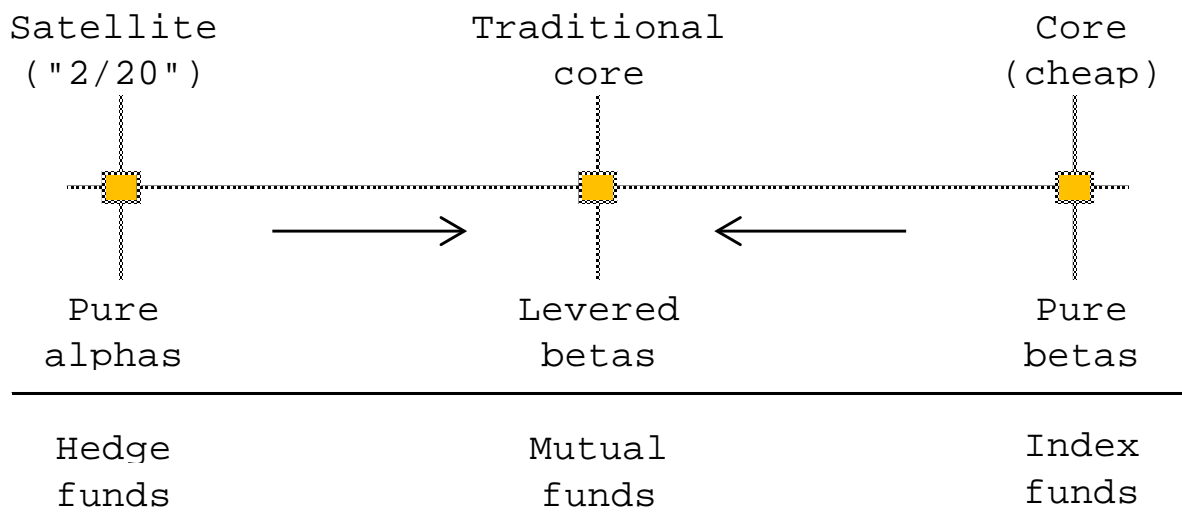

Yellow boxes indicate the presence of securities financing in each example (see Part II). In the case of pure beta index funds, securities financing is present either via "cash plus" derivative overlay strategies (where cash = repo) or the lending of securities that make up the index.⁵⁴

Source: Pozsar (2014)

Electronic copy available at: <https://ssrn.com/abstract=2558945>

Figure 25: Wholesale Funding and Levered (Bond) Betas - Flipsides of the Same Coin

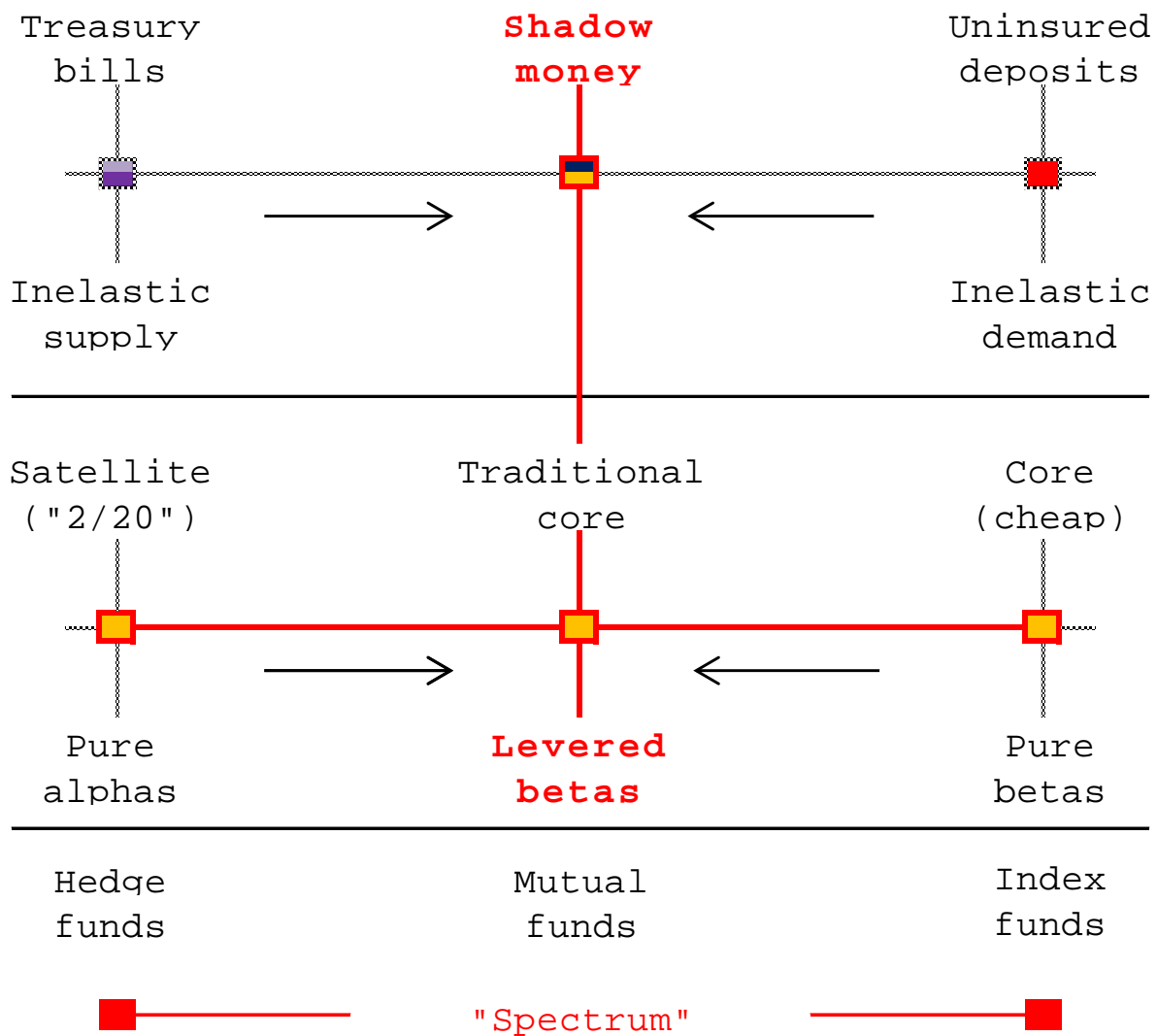
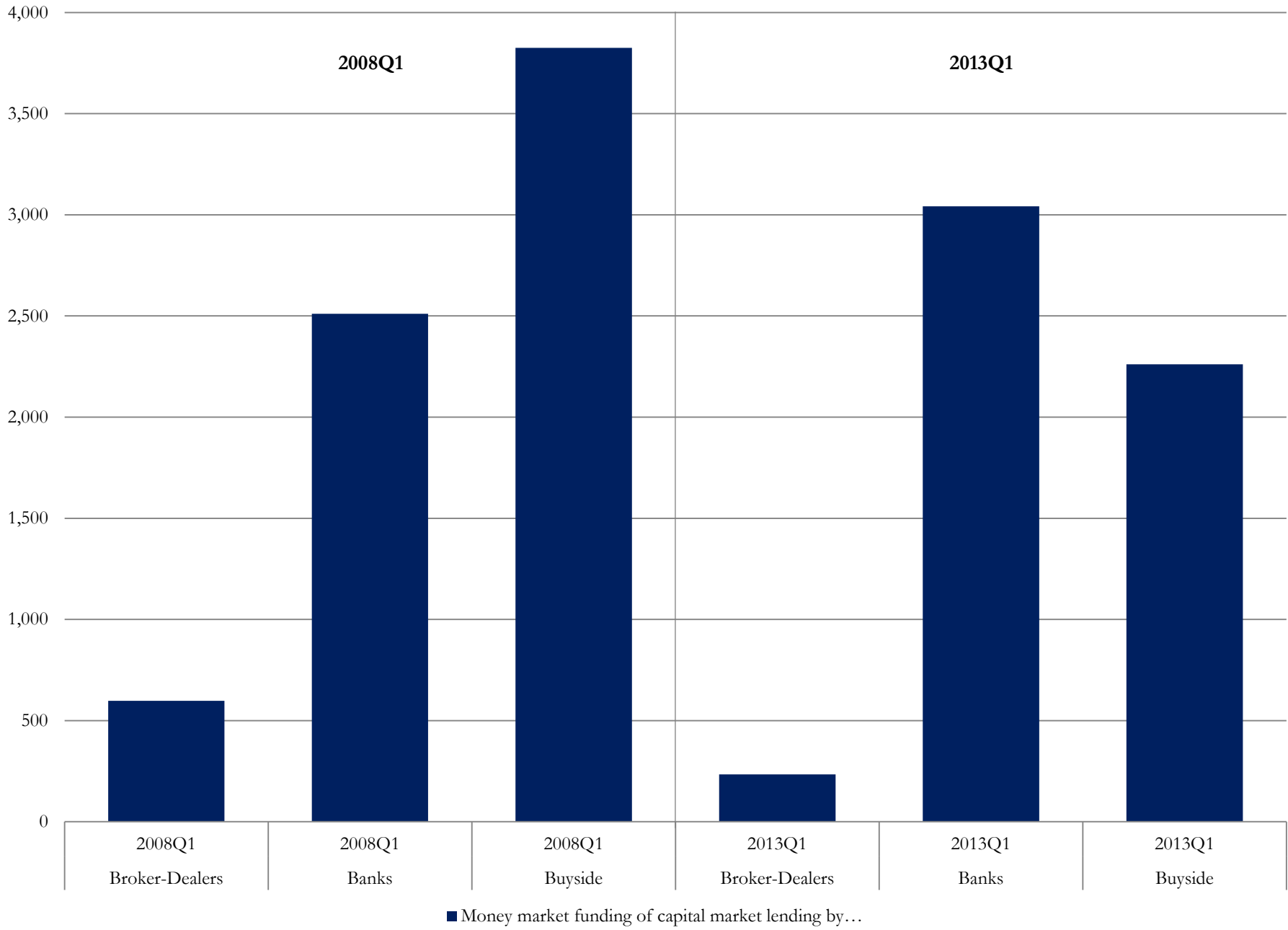
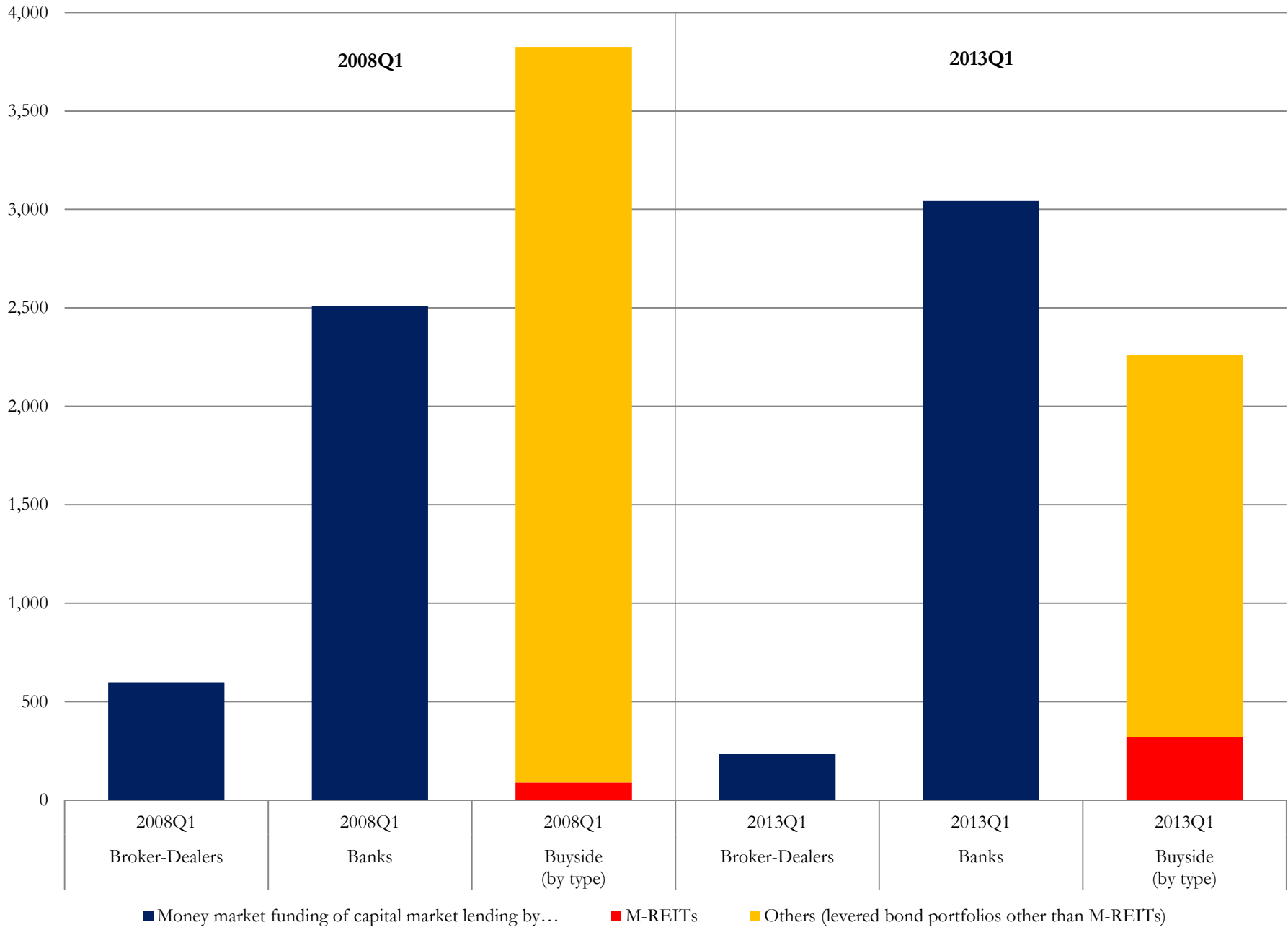

Figure 26: Three Sources of Levered Bids for Bonds (the Flow of Funds vs. Reality - again...)



Source: Federal Reserve Board (Flow of Funds) and Federal Reserve Bank of New York (FR2004)

Figure 27: We Cannot Monitor What We Do Not Measure and We Over-Monitor What We Can Measure



Source: Federal Reserve Board (Flow of Funds) and Federal Reserve Bank of New York (FR2004)

Figure 28: Levered Bids and the U.S. Treasury Term Premium vs. the Global Savings Glut

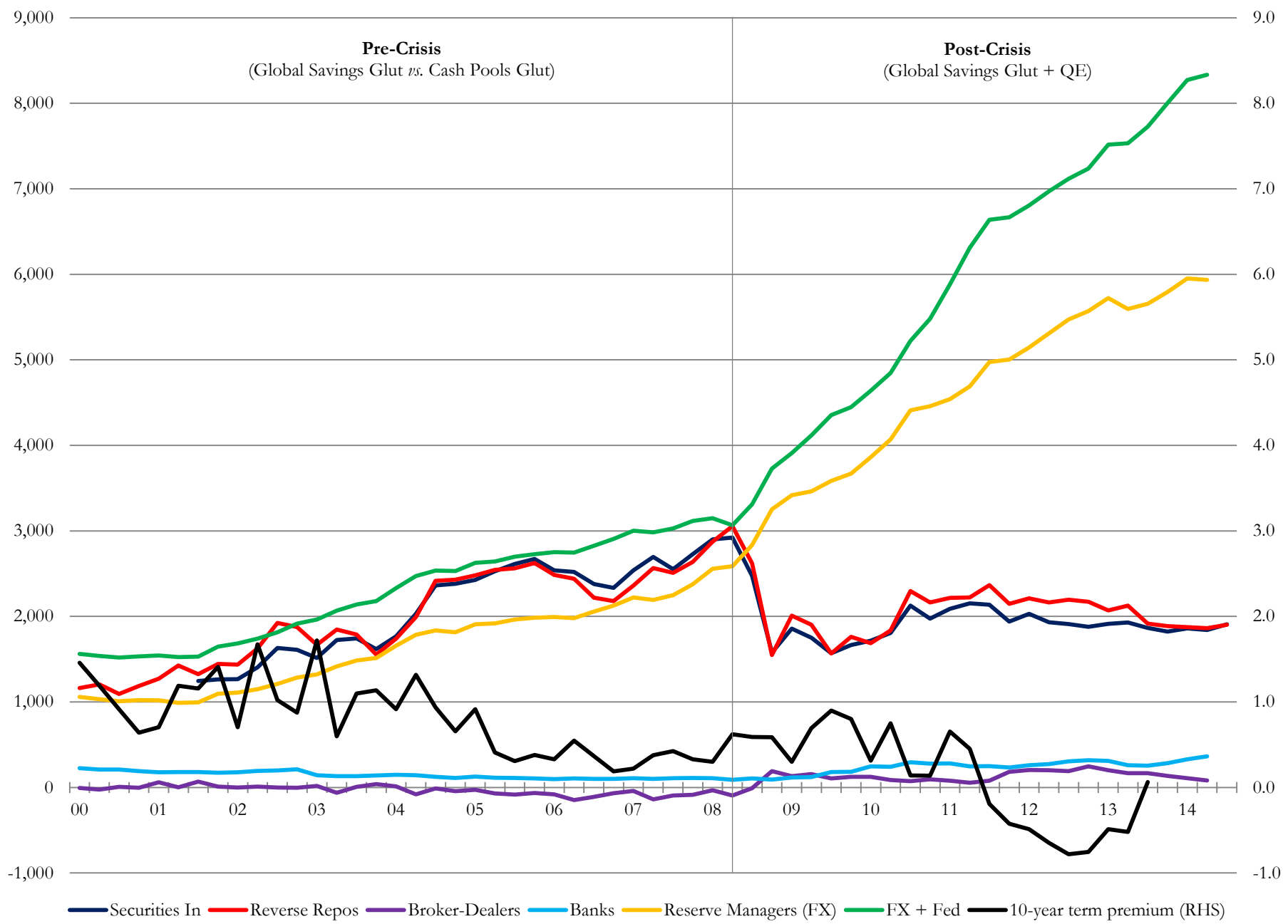

Source: Federal Reserve Board (Flow of Funds) and Federal Reserve Bank of New York (FR2004)

Figure 29: The Global Macro Context

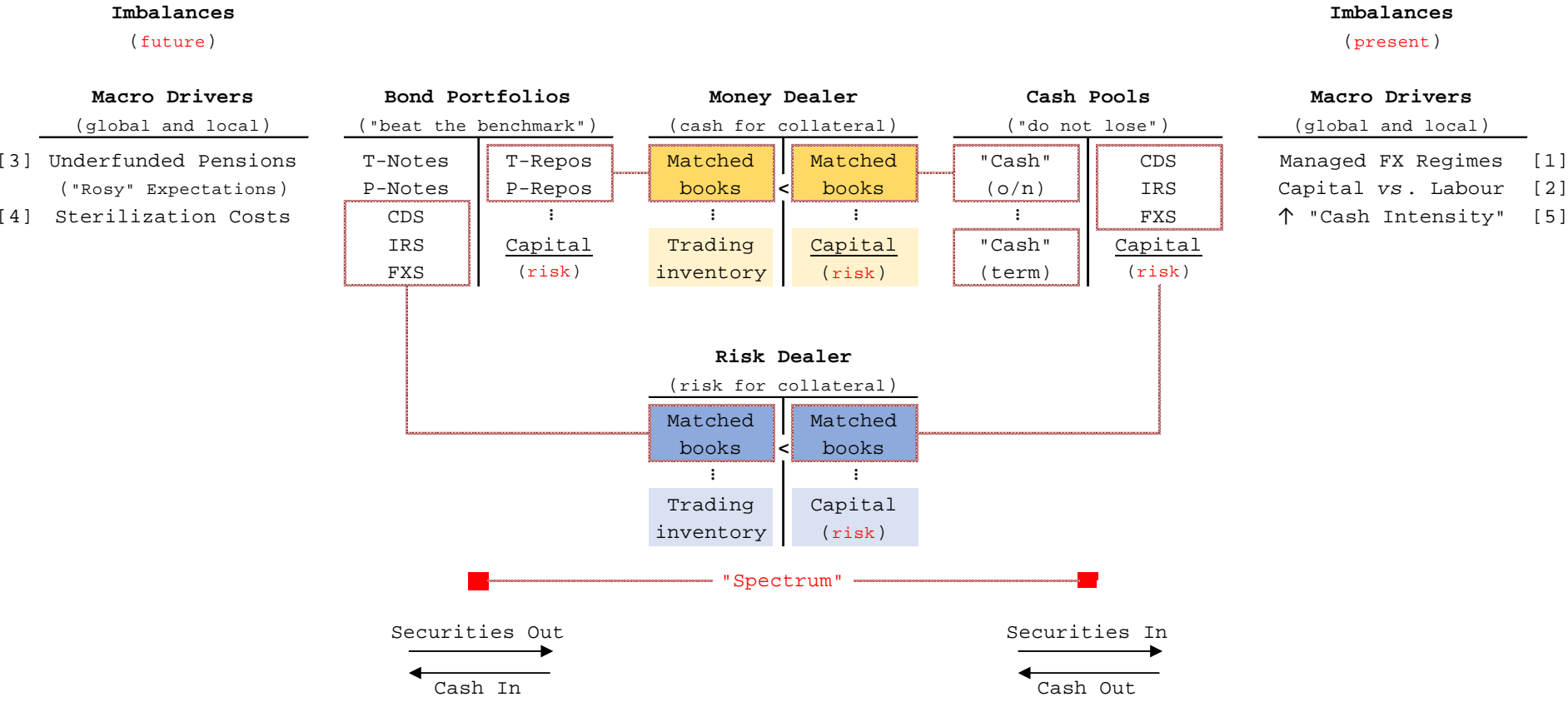

Source: Pozsar (2014) expanding on Mehrling, Pozsar, Sweeney and Neilson (2013)

Figure 30: Structural Asset-Liability Mismatches... (Funding Level of U.S. Public Pension Funds, %)

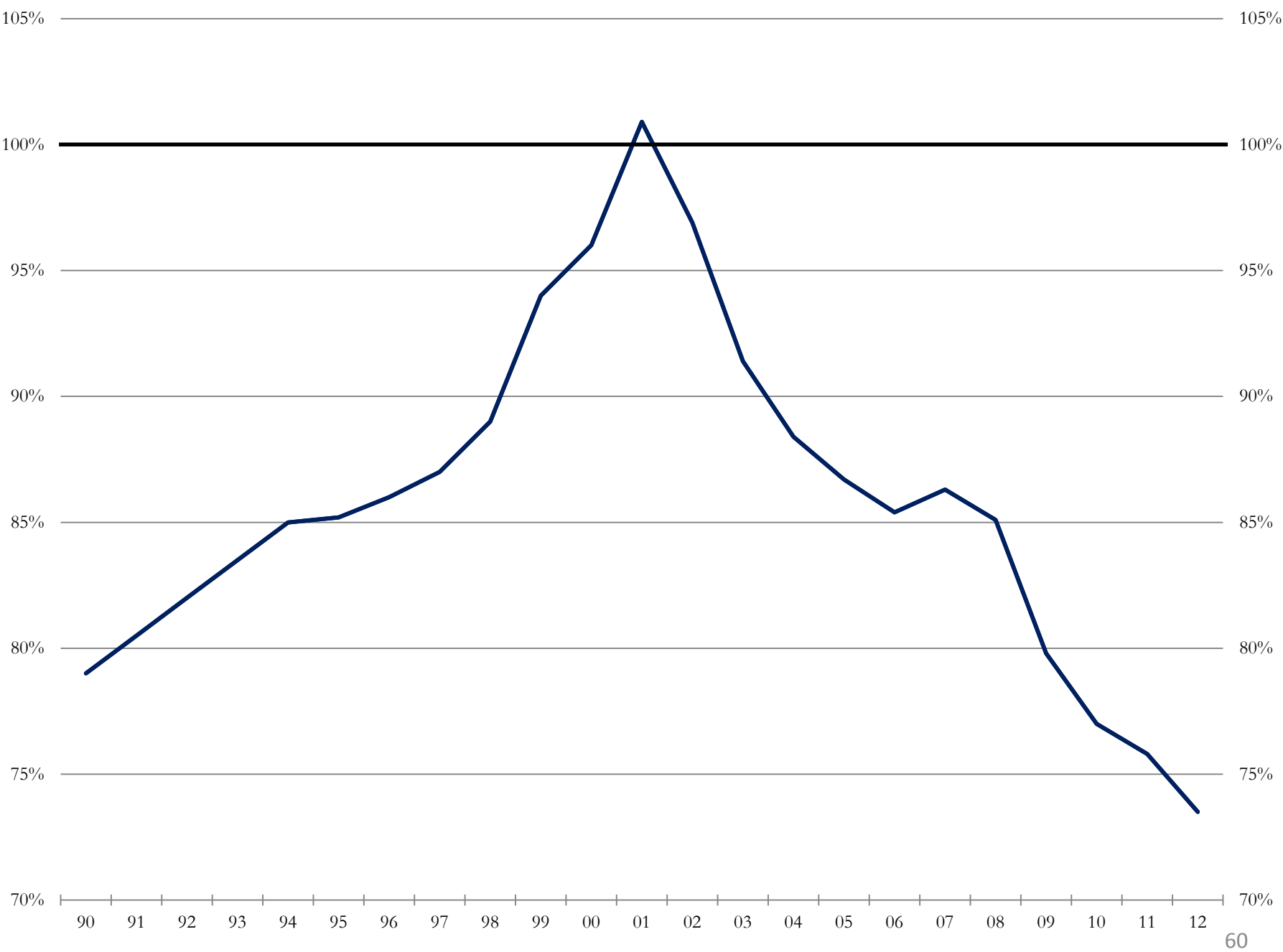

Source: Standard & Poor's pre-2000 and Public Fund Survey (November 2013) post-2000

Figure 31: ...Drive Demand for Equity-Like Returns With Bond-Like Volatility via Alternatives..., %

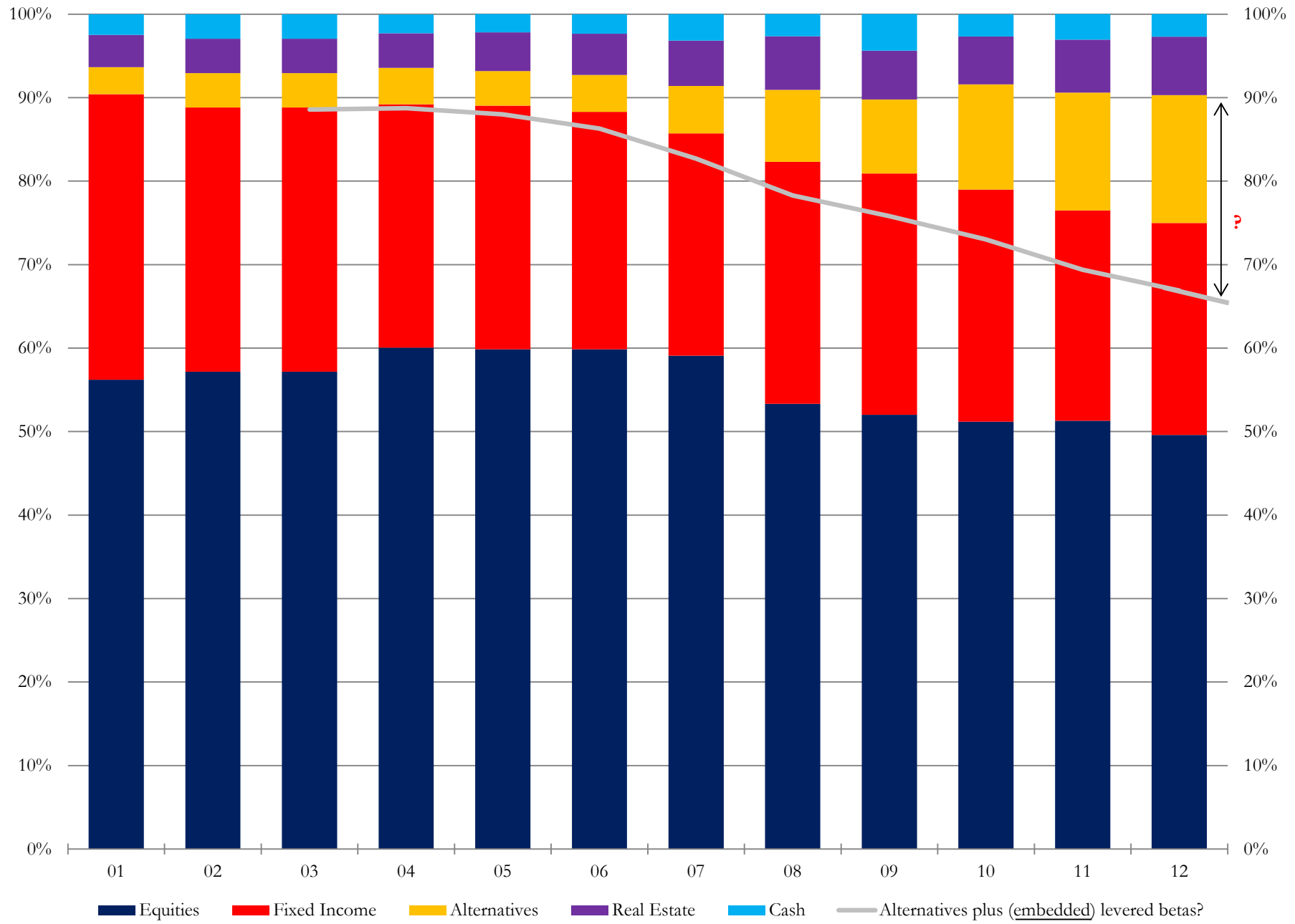

Source: Public Fund Survey (November 2013) [Electronic copy available at: https://ssrn.com/abstract=2558945](https://ssrn.com/abstract=2558945)

Figure 32: ...(a Trend that Intensifies With Greater Asset-Liability Mismatches)...

Funded ratio (x, %) vs allocation to risky assets (y, %) for weakest 10% of US public pension funds

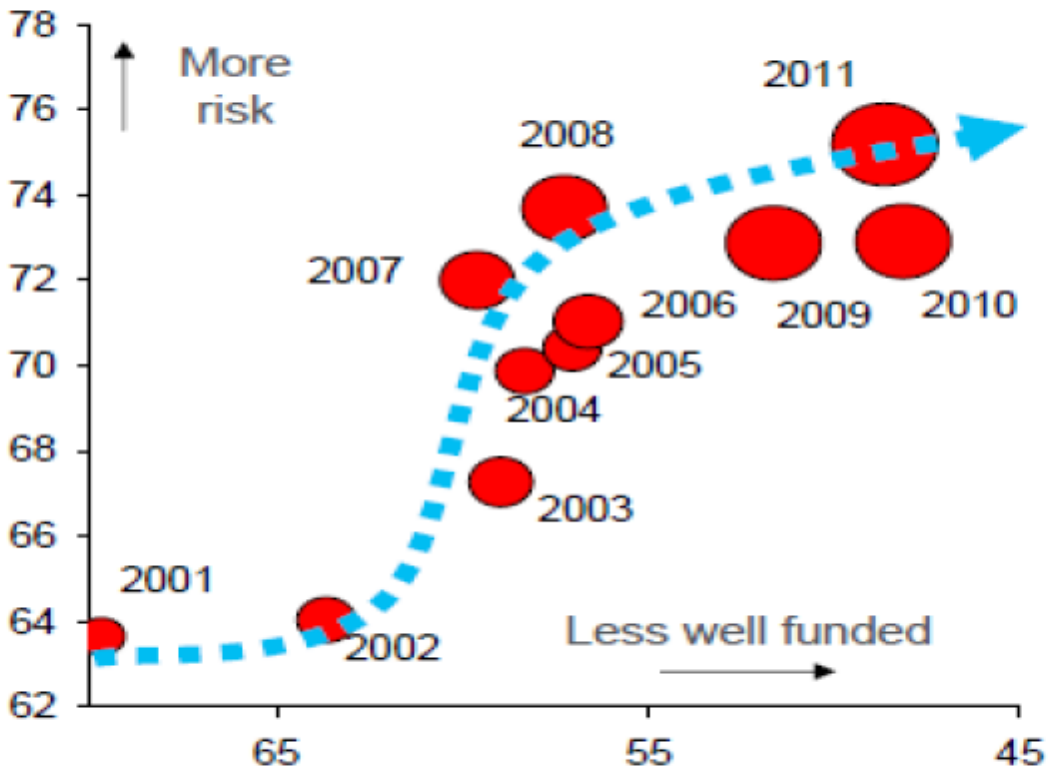

Source: IMF, Boston College Center for Retirement Research. Size of bubble represents allocation to alternatives.

Figure 33: ...and the Increased Lending of Low Intrinsic Value Securities for Reinvestment Income...

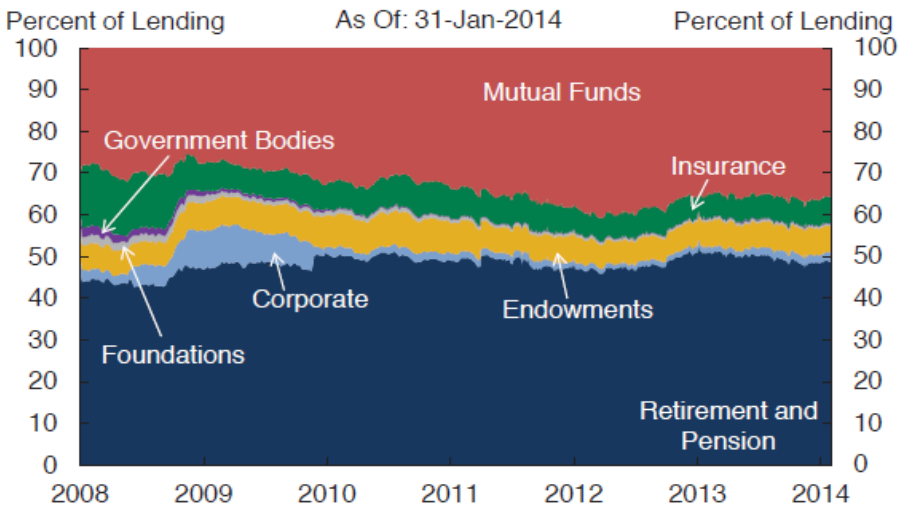

Source: Markit Group Limited

Note: Data is based on a survey of agent based lenders.

Securities loaned, \$ billions:

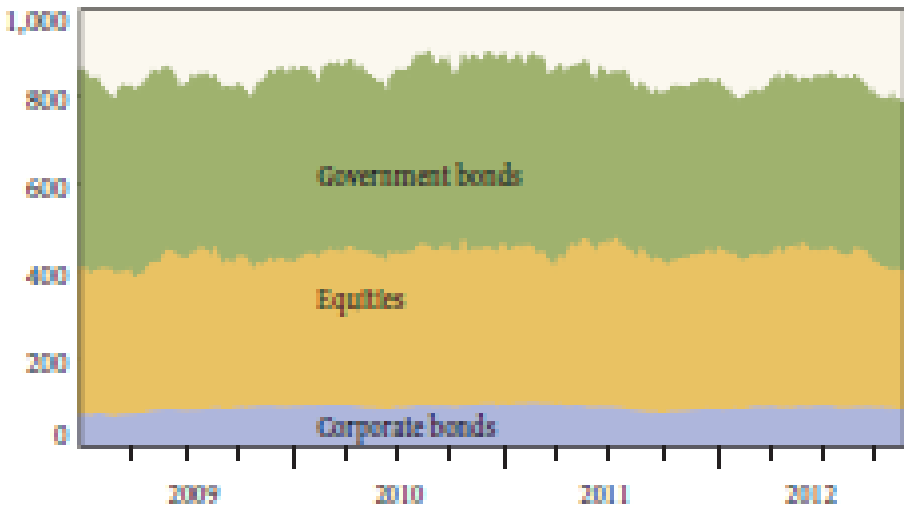

Source: Markit™ Group Limited.

Income from securities lending:

- Securities lending (fees)
- Cash reinvestment (revenues)

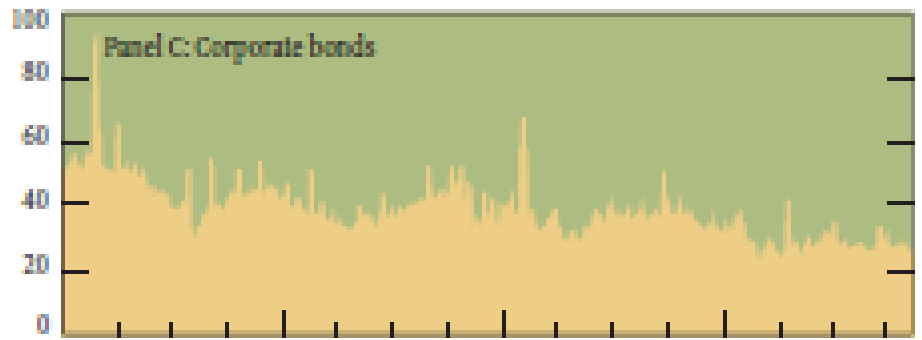
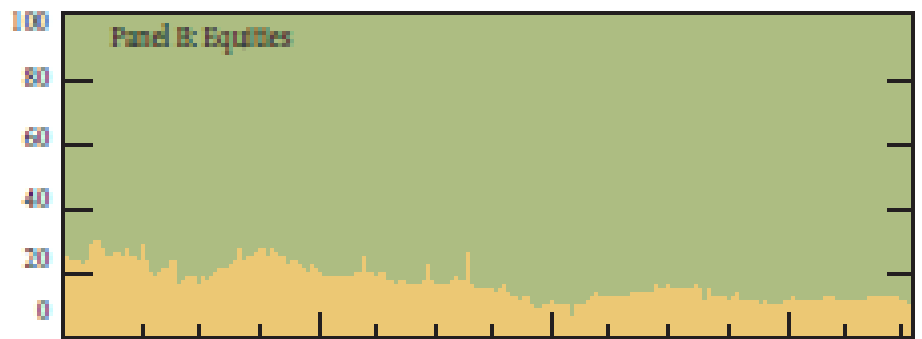
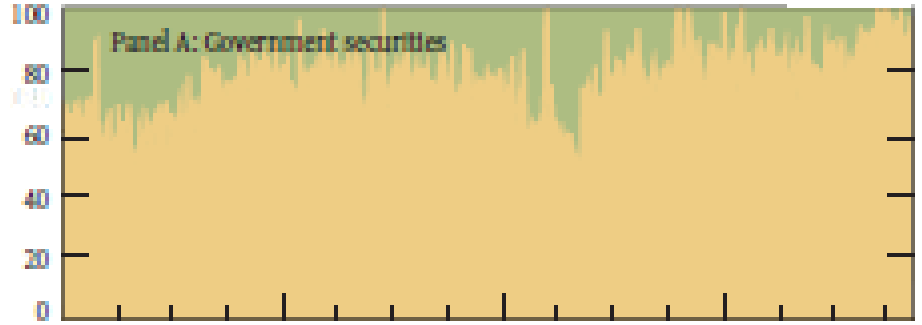

Source: Markit™ Group Limited via [Keane](#) (2013) and [FSOC](#) (2014)

Figure 34: ...All of Which is Funded by Broker-Dealers as Money Dealers..., \$ billion

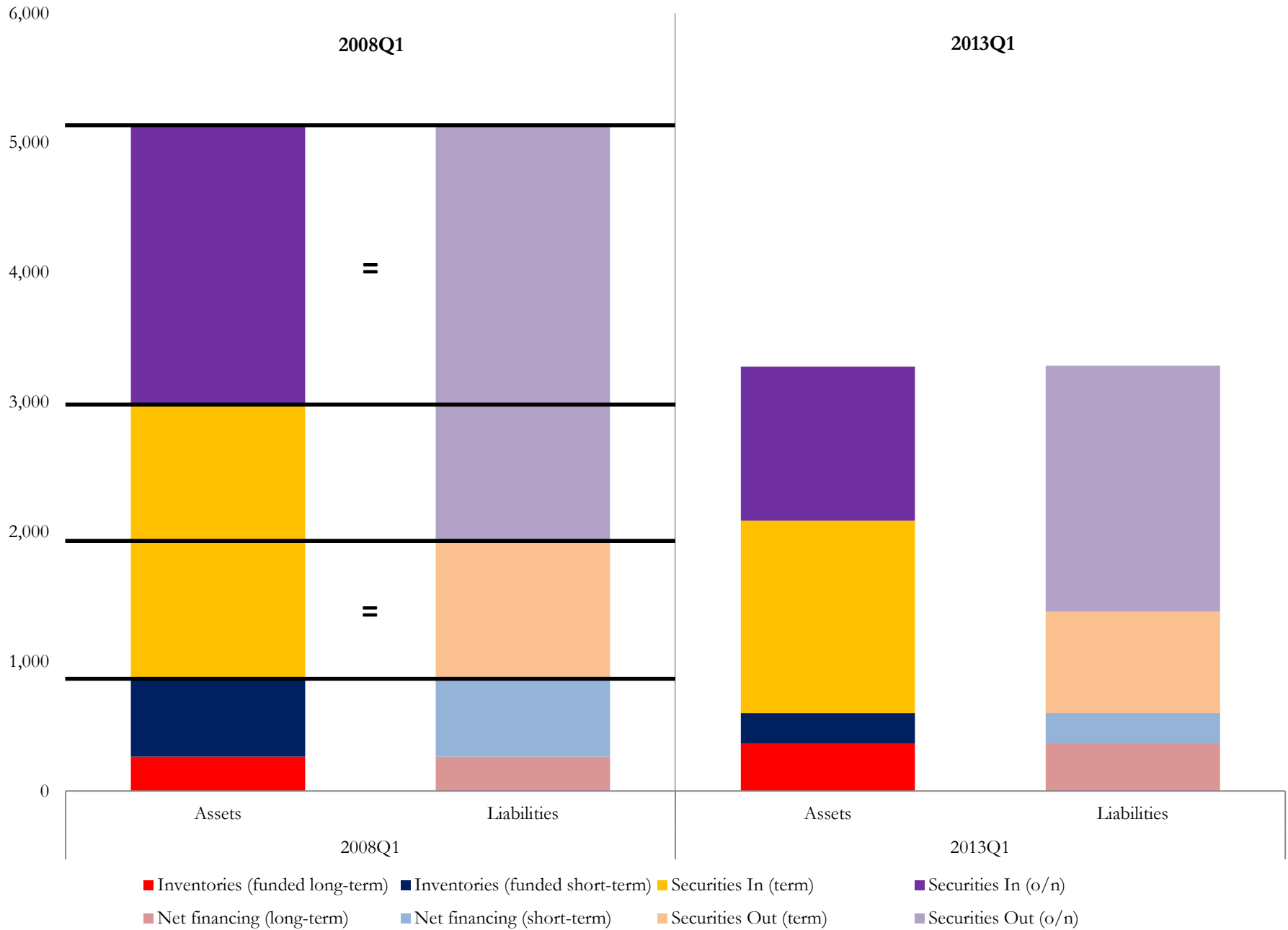

Source: Federal Reserve Board (Flow of Funds) and Federal Reserve Bank of New York (FR2004)

Figure 35: ...by Tapping into Cash Pools as Ultimate Providers of Wholesale Funding, \$ billion

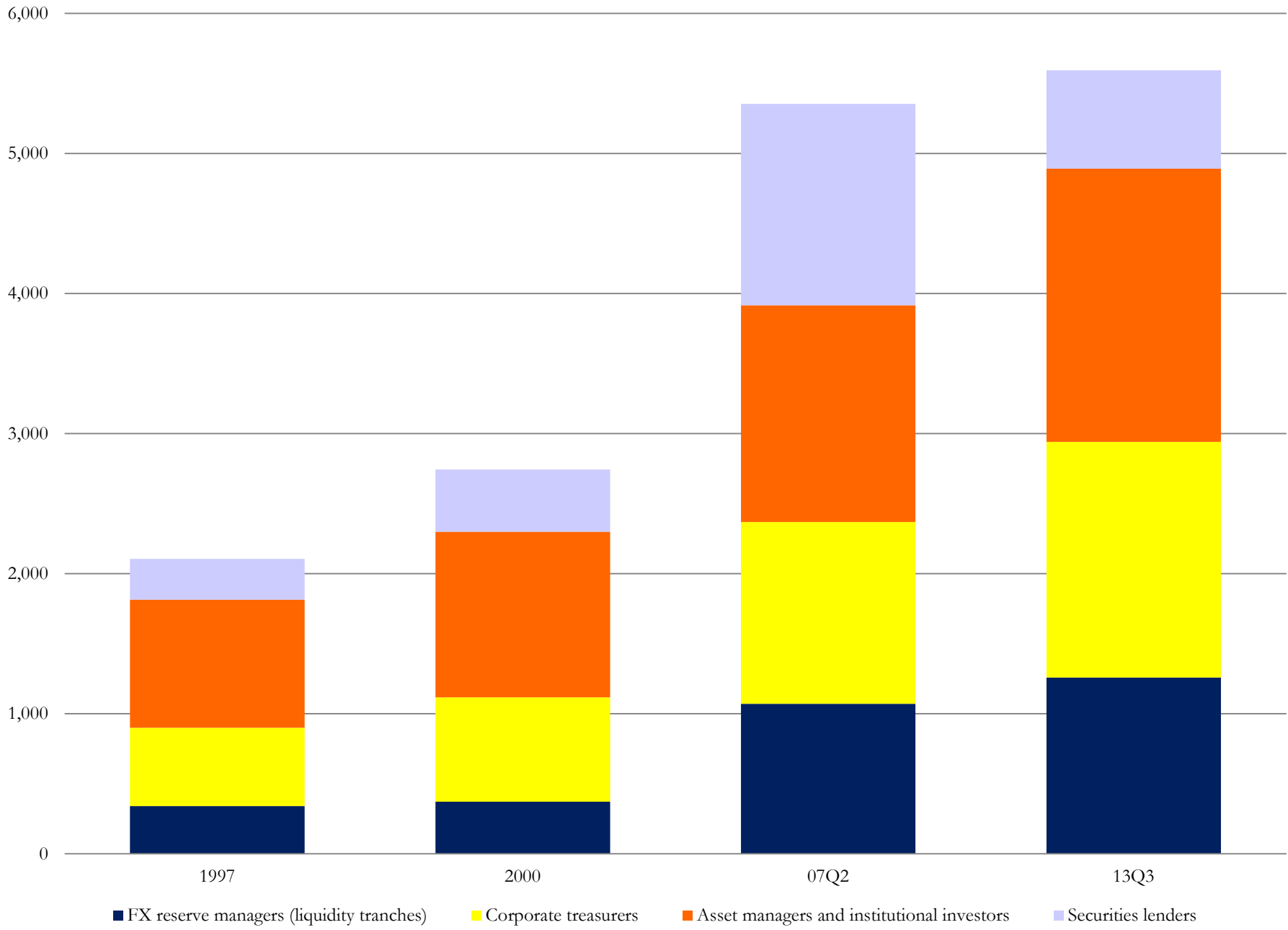

Figure 36: Four Simple Goals that Make the World Go 'Round

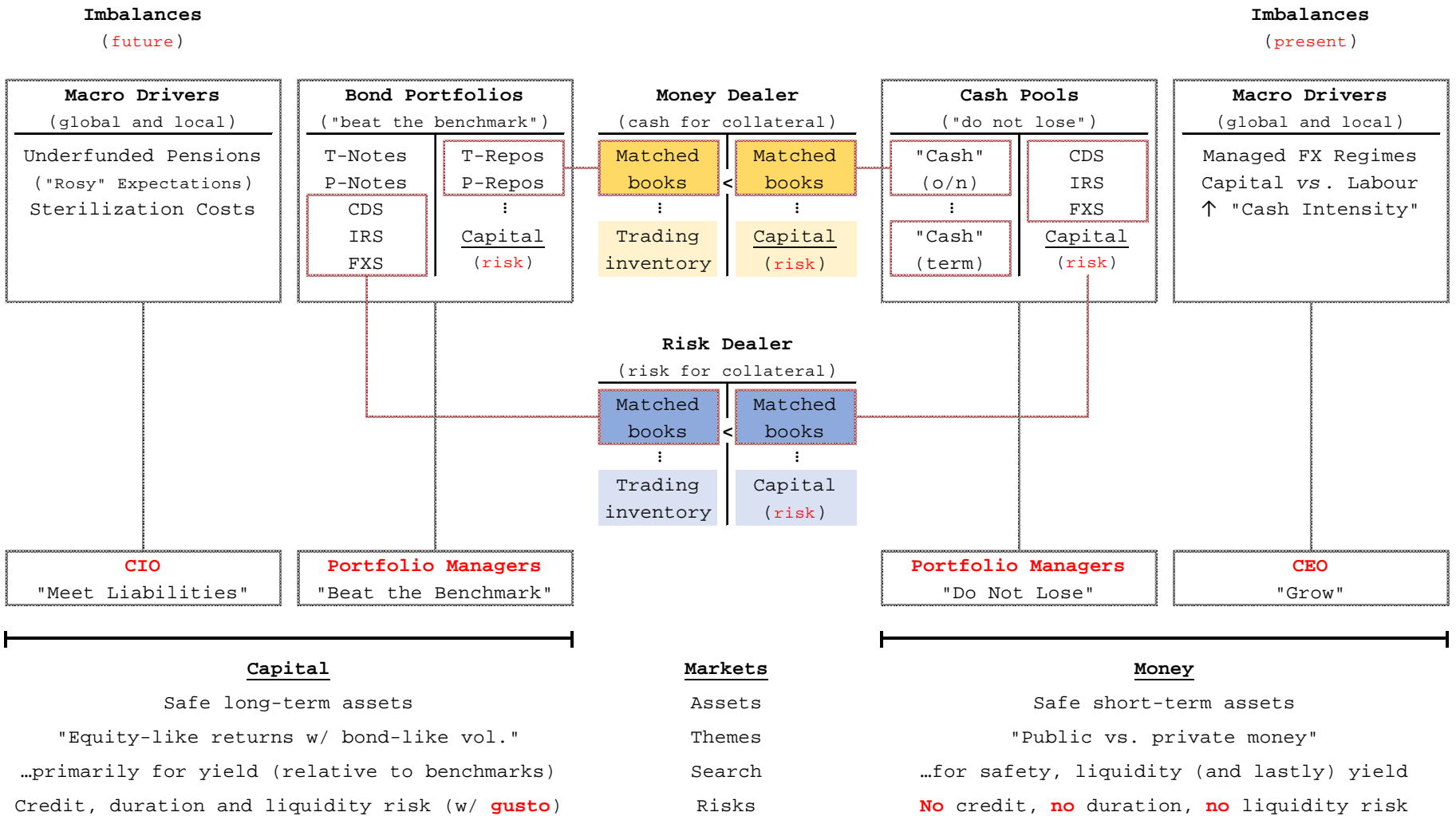
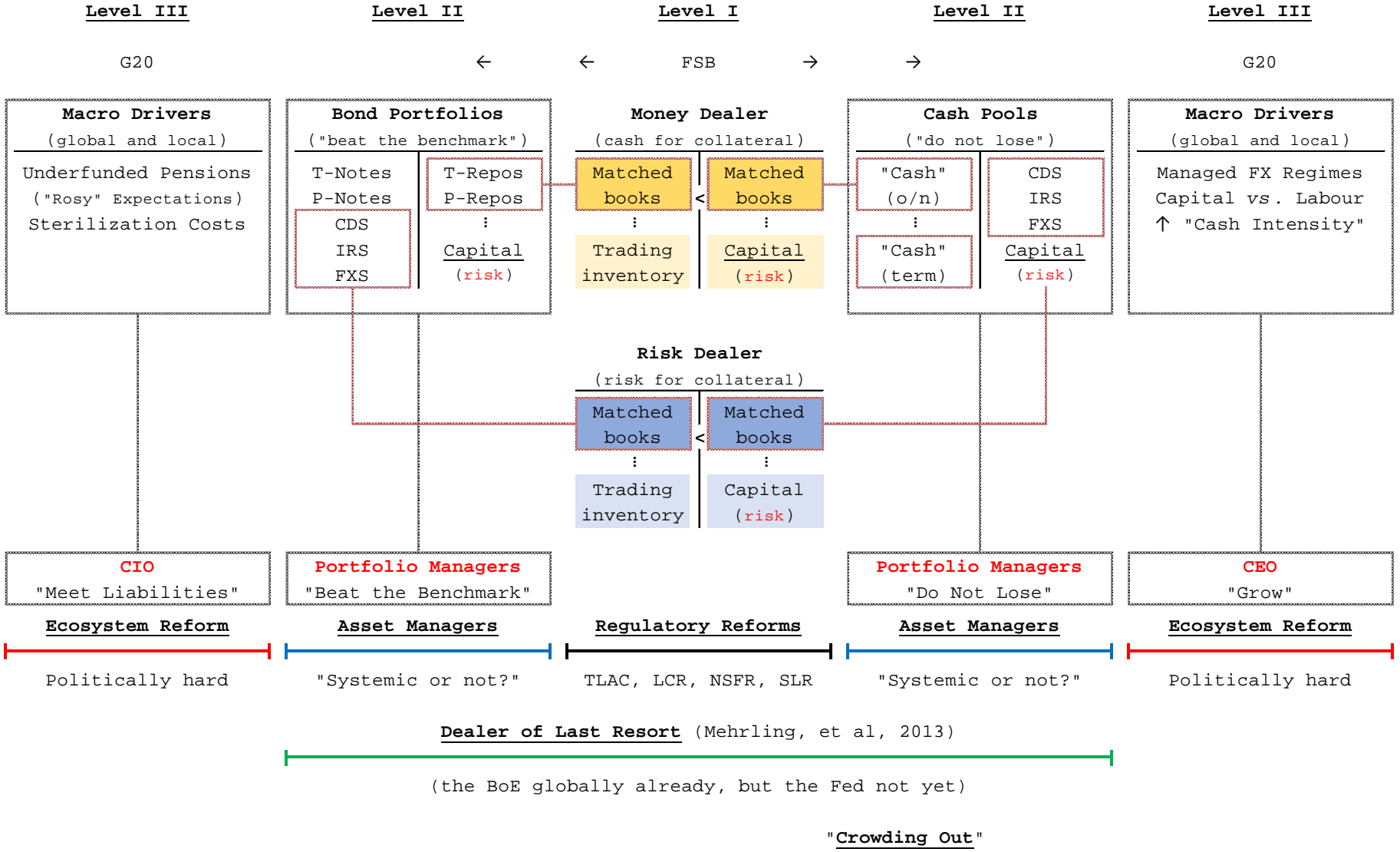

Figure 37: Implications for Governance



Source: Pozsar (2014)

Electronic copy available at: <https://ssrn.com/abstract=2558945> (public versus private money)

Figure 38: Crowding Out and Financial Flows

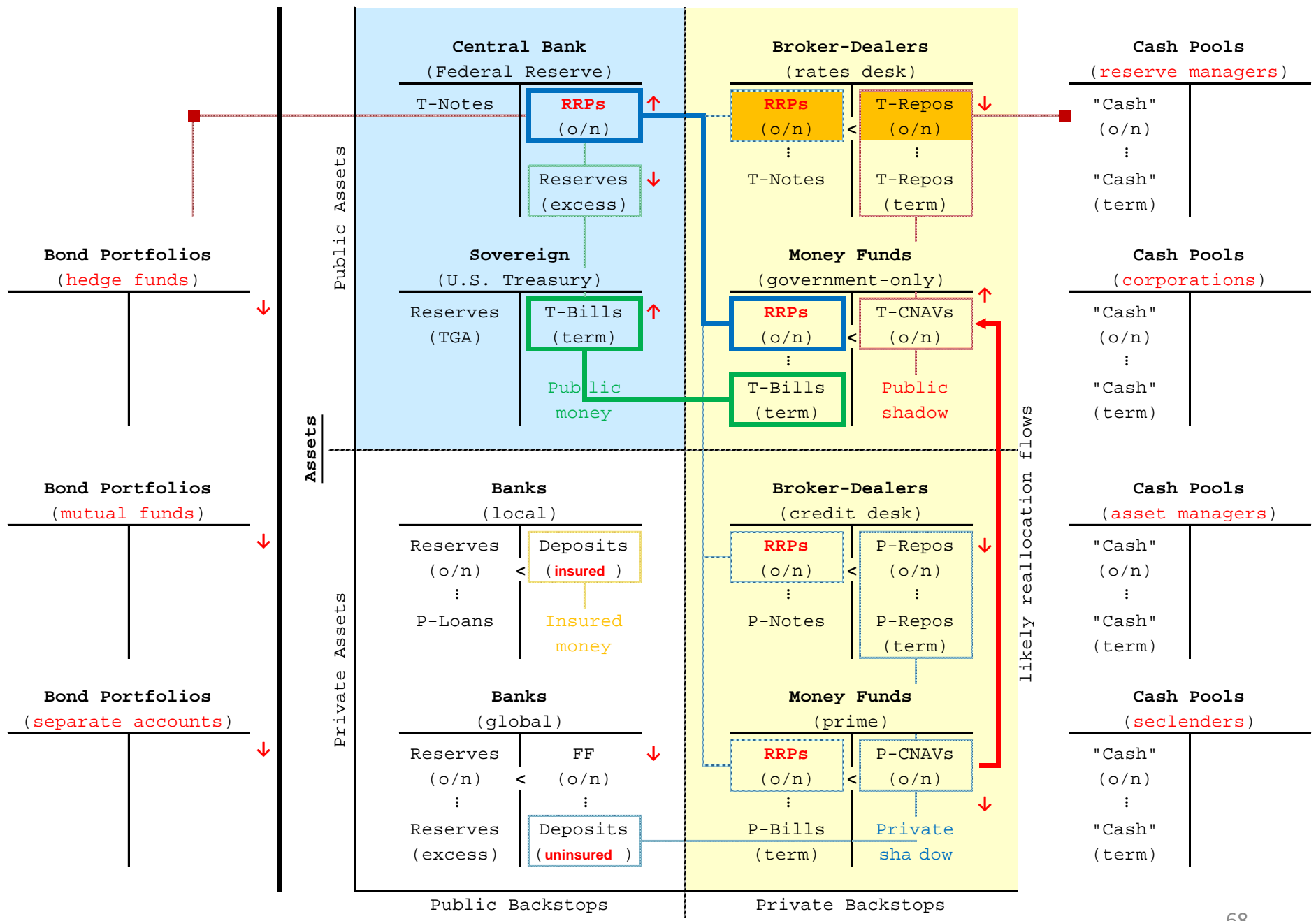

Source: Pozsar (2014)

References:

- Adrian, Tobias, Moench, Emanuel, and Shin, Hyun Song (2014), “Dynamic Leverage Asset Pricing”, FRBNY Staff Report No. 625, December.
- Asness, Clifford, Frazzini, Andrea and Pedersen, Lasse (2012), “Leverage Aversion and Risk Parity”, *Financial Analysts Journal*, Volume 68, Number 1.
- Bank of England (2013), “Liquidity insurance at the Bank of England: developments in the Sterling Monetary Framework”, October.
- Bank of England (2013), “Central banks announce standing swap arrangements”, October.
- Bank of England (2014), “Market Notice on USD Repo Operations”, November.
- Bernanke, Ben (2005), “The Global Savings Glut and the U.S. Current Account Deficit”, remarks at the Sandridge Lecture, Virginia Association of Economists, Richmond, Virginia, March.
- BIS (2014), “The ascent of the asset management sector”, Chapter 6, 84th Annual Report, June.
- BIS (2014), “Market-making and proprietary trading: industry trends, drivers and policy implications”, CGFS Papers No. 52, November.
- Brunnermeier, Markus (2009), “Deciphering the Liquidity and Credit Crunch 2007-2008”, *Journal of Economic Perspectives*, Volume 23, Number 1, Winter 2007, pp. 77-100.
- Caballero, Ricardo (2013), “The Shortage of Safe Assets: Macroeconomic Policy Implications”, presentation at the Bank of England, March.
- Carney, Mark (2014), speech at the Mansion House Bankers and Merchants Dinner, London, June.
- Cecchetti, Stephen (2011), “Global imbalances: current accounts and financial flows”, remarks at the Myron Scholes Global Markets Forum, University of Chicago, September.
- Citi (2014), “Enhanced Uses of Supply through Asset and Collateral Optimization and the Impact on the Securities Lending Markets”, October.
- Claessens, Stijn, Zoltan Pozsar, Lev Ratnovski, and Manmohan Singh (2012), “Shadow Banking: Economics and Policy”, IMF Staff Discussion Note 12/12.
- Dalio, Ray (2004), “Engineering Targeted Returns & Risks” Bridgewater Associates.
- Dooley, Michael, Folkerts-Landau, David, and Garber, Peter (2014), “The Revived Bretton Woods System’s First Decade”, NBER working paper No. 20454, September.
- Feroli, Michael, Kashyap, Anil, Schoenholtz, Kermit, Shin, Hyun Song (2014), “Market Tantrums and Monetary Policy”, February 2014 conference draft.
- Foley, Stephen, (2014), “When use of pseudo-maths adds up to fraud”, *Financial Times*, April 16.
- Geithner, Timothy (2014), “Stress Test”, Crown Publishers.
- Gorton, Gary and Metrick, Andrew (2012), “Who Ran on Repo”, NBER working paper, October.

- Greenwood, Robin, Hanson, Samuel and Stein, Jeremy (2010), “A Comparative-Advantage Approach to Government Debt Maturity”, Harvard Business School WP No. 11-035.
- Greenwood, Robin, Hanson, Samuel, Rudolph, Joshua and Summers, Lawrence (2014), “Government Debt Management at the Zero Lower Bound”, working paper, September.
- Gross, Bill (2003a), “Two Different Worlds (We live in...)”, PIMCO, November.
- Gross, Bill (2003b), “Imagine”, PIMCO Investment Outlook, December.
- Gross, Bill (2014a), remarks delivered by Bill Gross of PIMCO at the Morningstar Investment Conference, June.
- Gross, Bill (2014b), “Bill Gross’ Farewell Letter to PIMCO”, Bloomberg, October.
- G20 (2014), “Communique of the Meeting of G20 Finance Ministers and Central Bank Governors”, Cairns, Australia, September 20-21.
- Haldane, Andrew (2014), “The age of asset management?”, speech at the London Business School, London, April.
- IMF (2014), “Chapter 1: Improving the Balance between Financial and Economic Risk Taking”, GFSR, October.
- Keane, Frank (2013), “Securities Loans Collateralized by Cash: Reinvestment Risk, Run Risk and Incentive Issues”, FRBNY Current Issues in Economics and Finance, Vol. 12, No. 3.
- Krishnamurthy, Arvind and Vissing-Jorgensen, Annette (2012), “The Aggregate Demand for Treasury Debt”, *Journal of Political Economy*, Vol. 120, No. 2 (April 2012) pp. 233-267.
- Mackenzie, Michael and Meyer, Gregory (2014), “Gross triggers sell-off in interest rate derivative Positions”, *Financial Times*, October 5.
- McCauley, Robert and Rigaudy, Jean-Francois (2010), “Managing foreign exchange reserves in the crisis and after”, BIS Papers No. 58.
- McCauley, Robert and McGuire, Patrick, (2014), “Non-US banks’ claims on the Federal Reserve”, *BIS Quarterly Review*, March.
- McGuire, Patrick and von Peter, Goetz (2009), “The U.S. dollar shortage in global banking”, *BIS Quarterly Review*, March, 2009.
- Mehrling, Perry (2011), *The New Lombard Street: How the Fed Became the Dealer of Last Resort*, Princeton University Press.
- Mehrling, Perry (2011), “Financial Globalization versus the Nation State”, blog, February 27.
- Mehrling, Perry, Zoltan Pozsar, James Sweeney, and Daniel Neilson (2013), “Bagehot was a Shadow Banker: Shadow Banking, Central Banking, and the Future of Global Finance”, INET.
- Mehrling, Perry (2014), “Eurodollars: Parallel Settlement”, lecture notes from Money and Banking, Coursera, September.
- OECD (2013), “Action Plan on Base Erosion and Profit Shifting”.

- Pozsar, Zoltan, Tobias Adrian, Adam Ashcraft, and Hayley Boesky (2010), “Shadow Banking”, New York Fed Staff Report No. 458, July.
- Pozsar, Zoltan (2011), “Institutional Cash Pools and the Triffin Dilemma of the U.S. Banking System”, IMF Working Paper No. 11/190.
- Pozsar, Zoltan and Singh, Manmohan (2011), “The Nonbank-Bank Nexus and the Shadow Banking System”, IMF Working Paper No. 11/289.
- Pozsar, Zoltan (2012), “A Macro View of Shadow Banking: Do T-Bill Shortages Pose a New Triffin Dilemma?”, in Franklin Allen et al (eds.), *Is U.S. Government Debt Different?*, pp. 35–44.
- Pozsar, Zoltan (2013), “Shadow Banking and the Global Financial Eco-System”, VoxEU, November 6.
- Pozsar, Zoltan (2014), “Shadow Banking: The Money View” OFR Working Paper 14-04, July.
- Rajan, Raghuram (2011), “Fault Lines: How Hidden Fractures Still Threaten the World Economy”, Princeton University Press, August.
- Shin, Hyun Song (2010a), “Financial Intermediation and the Post-Crisis Financial System”, BIS Working Paper No. 304.
- Shin, Hyun Song (2010b), “Non-Core Liabilities Tax as a Tool for Prudential Regulation”, Policy Memo, February 19.
- Shin, Hyun Song (2012), “Global Banking Glut and Loan Risk Premium”, paper presented at the 12th Jacques Polak Annual Research Conference, IMF, Washington, D.C., November 10-11.
- Soros, George (2003), “The Alchemy of Finance”, Wiley Investment Classics, July.
- Stein, Jeremy (2011), “Monetary Policy as Financial-Stability Regulation”, NBER working paper.
- Stein, Jeremy (2012), “Dollar Funding and Global Banks”, speech at the Global Research Forum, International Finance and Macroeconomics sponsored by the ECB, December.
- Summers, Lawrence (2013), “Why stagnation might prove to be the new normal”, Financial Times, December 15.
- Turner, Adair (2013), “Credit, Money and Leverage: What Wicksell, Hayek and Fisher Knew and Modern Macro Forgot”, INET working paper, September.